

Exploded View

Sale Model:

PIAWMZ488800B

Power Supply:

208/230V,1Ph

Export Time:

2023-02-16 17:28:19

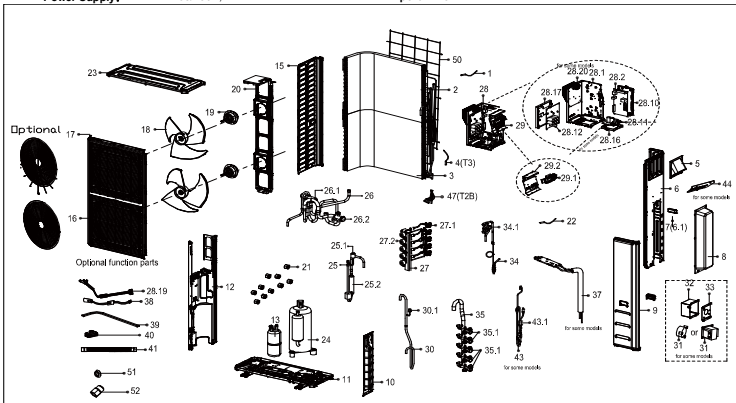

No.	Chinese Name	Part Name	Quantity	BOM Code	Price	Remark1	Remark2
1	室温传感器	Ambient temperature sensor sub	1.0	11201007003448	0.324	CGQ-WD/SW4100-L850	
2	冷凝器部件	Condenser assembly	1.0	15822000008539	106.392		
3	冷凝器部件	Condenser assembly	1.0	15822000008537	106.308		
4	管温传感器	Pipe temperature sensor	1.0	11201007003441	0.384	CGQ-WD/GW4100-L120	
5	大把手组件	Handle assembly	1.0	12222300000039	1.212		
6	右后侧板部件	rear right side plate assembly	1.0	1222200012227	12.564		
6.1	抓手	handle	1.0	12100702000038	0.084		
8	接水盖	Water collector	1.0	12122000014341	2.64		
9	右前侧板部件	Front clashboard assembly	1.0	12222000006287	11.028		
10	阀安装板	Valve plate	1.0	12222000006744	3.984		
11	底盘部件	Fixing plate on chassis	1.0	12222000006290	14.808		
12	隔板部件	Partition board subassembly	1.0	12222000005733	9.228		
13	贮液筒	accumulator cylinder	1.0	15500508000009	12.024	ZYT-10	
15	左侧板部件	Left supporter	1.0	12222000002363	8.028		
16	出风网罩	Air outlet grille	2.0	12222000014845	5.436		
17	前面板	Front panel	1.0	12222000007564	16.872		
18	轴流风叶	axial flow fan	2.0	12100105000022	4.272	ZL-554*148*12-3KFN	
19	无刷直流电机	Outdoor fan motor	2.0	11002015009825	19.2	ZKFN-85-8-22-5	
20	电机支架组件	Motor bracket assembly	1.0	12222000006288	10.884		
21	铜螺母	Copper nut	5.0	15500406000012	0.3	TLM-A01	
21	铜螺母	Copper nut	2.0	15500406000012	0.66	TLM-C03	
21	铜螺母	Copper nut	3.0	15500406000010	0.492	TLM-B02	
22	排气温度传感器	Discharge temperature sensor a	1.0	11201007003124	0.528	CGQ-WD/PQ3950-11000-XHRCP28K-G950	
23	顶部部件	Top cover assembly	1.0	12222200002359	7.5		
24	变频旋转式压缩机	compressor	1.0	11103020000619	173.088	ATQ360D1UMU	
25	压缩机排气管部件	compressor discharge pipe suba	1.0	15122000026303	16.26		
25.1	压力控制器	Pressure switch	1.0	17400516000851	2.856	YK-4.4/3.2-500-1	
25.2	消声器	Muffler	1.0	15500506000002	5.976	XSQ-07	
26	四通阀部件	4-ways valve or Gas valve asse	1.0	15422000017697	45.168		
26.1	四通阀	4-way valve	1.0	15500216000681	20.688	STF-03BN1	
26.2	低压阀	Gas valve	1.0	15500204000049	8.832	DVF-D-19-19N1	
27	高压阀部件	High pressure valve subassembly	1.0	15422000021257	79.452		
27.1	高压阀	High pressure valve	5.0	15500208000028	1.536	GYF-A28N	
27.2	电子膨胀阀	Electronic expansion valve	5.0	15500213000265	14.292	DPF(T01)2, 0C-04(L=1500)	
28	外箱变频室外电控盒组件	Electronic control box subasse	1.0	172220000037757	193.344		
28.1	电器安装板组件	Electrical installation plate	1.0	12222000012372	4.152		
28.2	外箱变频室外主控制板组件	Outdoor main control board sub	1.0	17122000055770	34.788		
28.10	电控安装盒	Electronic installing box	1.0	12122000014342	0.948		
28.12	变频模块组件(室外)	Inverter module subassembly	1.0	17122000055772	140.412		
28.17	电控安装盒	Electronic installing box	1.0	12122000020943	1.704		
28.19	压缩机连接组	compressor connection cable	1.0	17401203000936	5.172		
29	电控盒端子板组件	Electronic control box termina	1.0	172220000037758	16.08		
29.1	接线座	Terminal block	1.0	17400401003456	1.164	IXZ-PG3ZG1-A	
29.1	接线座(6位)	Terminal block	1.0	17400401000135	1.14	IXZ-PD6Z-C	
29.1	接线座(9位)	Terminal block	1.0	17400401000084	1.68	IXZ-PD9Z-C	
29.2	端子安装板组件	Terminal board assembly	1.0	122223000000729	0.864		
30	压缩机回气管部件	compressor suction pipe subass	1.0	15122000013597	7.584		
30.1	压力控制器	Pressure switch	1.0	17400516000848	2.508	YK-0.14/0.3-500	
34	高压阀部件	High pressure valve assembly	1.0	15422000017696	3.912		
34.1	高压阀	High pressure valve	1.0	15500208000047	3.132	GYF-A-8-8N1	
35	低压阀部件	Gas valve assembly	1.0	15422000007215	22.536		
35.1	低压阀	Gas valve	2.0	15500204000058	3.012	DVF-R29N	
35.1	低压阀	Gas valve	3.0	15500204000021	2.484	DVF-A28N	
37	铜管铝板散热器组件	Radiator subassembly	1.0	15122000029642	16.308		
38	曲轴电加热带	compressor electric heater	1.0	17402001000602	2.22		
39	电加热管	Electric heater of chassis	1.0	17402002000466	7.812		
43	电子膨胀阀组件	Electronic expansion valve sub	1.0	15422000021258	29.316		
43.1	电子膨胀阀	Electronic expansion valve	1.0	15500213001405	19.536	DPF(T01)3, 2C	
44	挡水板	Waterproof Board	1.0	12222000013398	0.384		
47	管温传感器	Pipe temperature sensor	1.0	11201007000142	0.696	CGQ-WD/GW4100-L1200-XHP12-P1140-05	
50	后网	Rear Grille	1.0	12222000007944	4.224		
52	管接头组件	transfer connector	2.0	15500303002547	1.452	ZHITZJ-6, 35-9, 52	
52	管接头组件	transfer connector	2.0	15500303002546	3.024	ZHITZJ-12, 7-16	
52	管接头组件	transfer connector	3.0	15500303002545	2.316	ZHITZJ-9, 52-12, 7	
52	管接头组件	transfer connector	2.0	15500303002544	2.508	ZHITZJ-12, 7-9, 52	