

标记	处数	设计变更内容	签名	日期

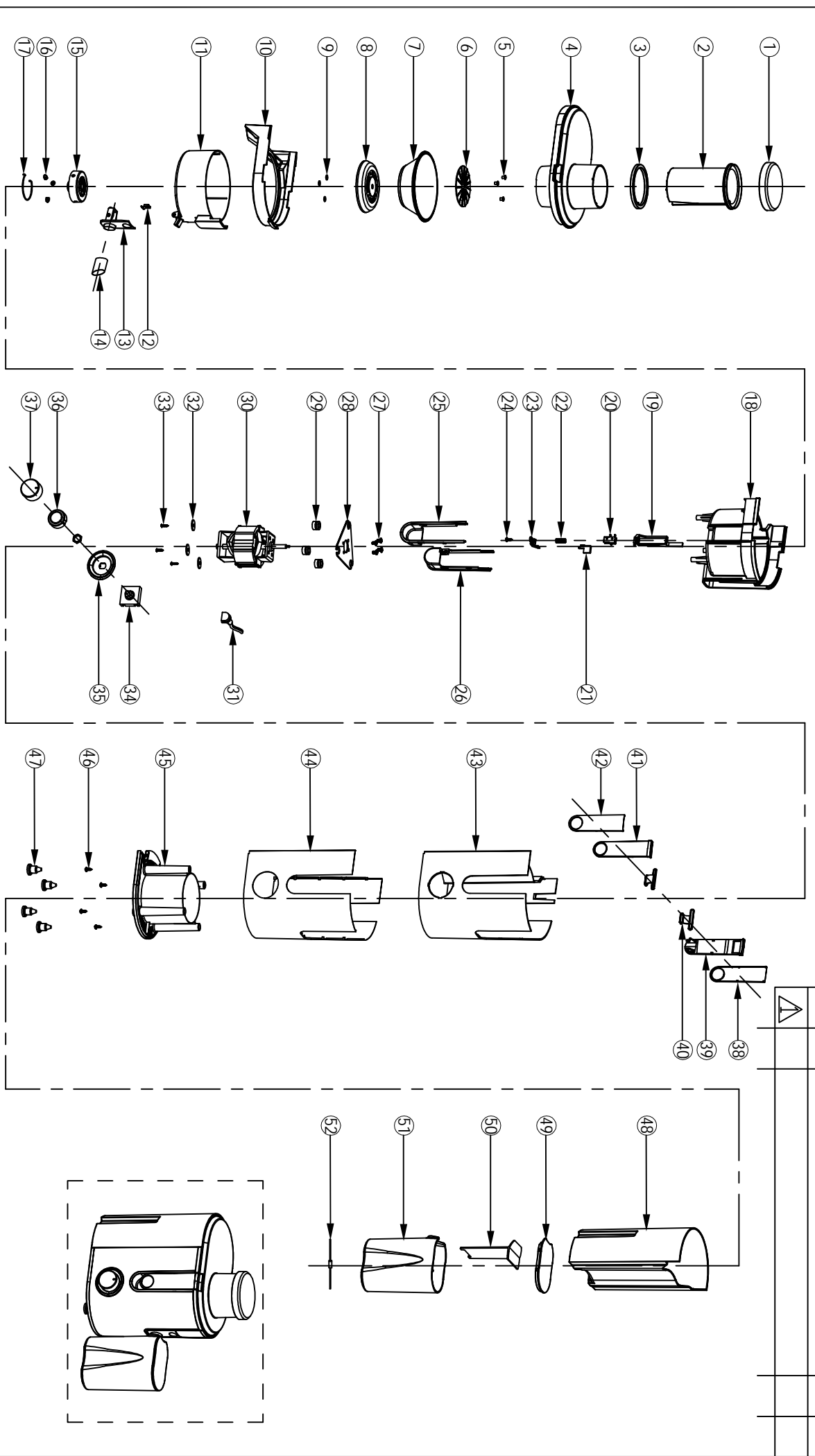

2017 12 18		MATERIAL		FINISHING		3RD ANGLES		SCALE		UNIT		m/m	
				±		±		1/1		F.		AO	
DRAWING NO.													

					设计变更内容		签名	日期		
					标记	处数	DESCRIPTION REVISIONS		Name	DATE
					SYM.	No.				
					△					
54				27	螺丝	M4×8大扁(φ8)带花	4			
53				26	337后扣手架	ABS	1			
52	二极管	6A 6A10	1	25	337前扣手架	ABS	1			
51	322接汁杯	PS	1	24	螺丝	S3×10十字带垫	1			
50	322接汁杯隔板	ABS	1	23	339微动开关压板	POM	1			
49	322接汁杯盖	ABS	1	22	401转动轴弹簧	弹力4.5N	1			
48	338接渣桶	PP	1	21	339推杆	POM	1			
47	401胶脚	TPE	4	20	301微动开关	5A 250V 带常闭假脚	1			
46	螺丝	S4×12盘头尖咀镀锌	4	19	339传动杆	POM	1			
45	338底座	ABS	1	18	339电机座	ABS	1			
44	339不锈钢外壳	SUS410#/0.3mm	1	17	306转座弹簧	镀锌钢丝/0.8mm	1			
43	339外壳	ABS	1	16	330转座弹珠	POM	3			
42	339前扣手饰板	SUS410#/0.3mm	1	15	330转座	POM+铁粉压铸	1			
41	339前扣手	ABS	1	14	308不锈钢出汁咀	SUS304#/0.4mm	1			
40	339扣手转轴	POM	2	13	338出汁咀	ABS	1			
39	339后扣手	ABS	1	12	338出汁咀弹片	POM	1			
38	339后扣手饰板	SUS410#/0.3mm	1	11	338接汁盘	ABS	1			
37	336旋钮	ABS	1	10	338接汁盘盖	ABS	1			
36	336旋钮内架	ABS	1	9	平垫	内φ4.2外φ8 不锈钢	3			
35	338旋钮开关支架	ABS	1	8	338网座	ABS	1			
34	306档位开关	250V/6A	1	7	338合成榨汁网	SUS430#	1			
33	螺丝	S4×12大扁尖咀镀锌	3	6	338榨汁刀板	SUS430#	1			
32	平垫	内φ4.2外φ16 镀锌	3	5	330刀板铆钉	SUS304#	3			
31	301电源线	外露1.2m	1	4	339面盖	PS	1			
30	电机	70#	1	3	336进料口环	HIPS	1			
29	310L减震环	原色硅胶 硬度30°	3	2	310推果棒	PP	1			
28	311电机板	镀锌板/1.8mm	1	1	336果棒盖	ABS	1			
序号	物料名称	规格及型号	用量	备注	序号	物料名称	规格及型号	用量	备注	
NO.	name	specification	QTY	remark	NO.	name	specification	QTY	remark	
	邱文浩									
	2017.12.20	MATERIAL		FINISHING		3RD ANGLE'S	SCALE	1/1	UNIT	
		±0.2 M/M			±		DESCRIPTION	爆炸图	REV.	
		TOLERANCES OTHERWISE SPECIFIC LENGTH ANGULAR					MODEL NO.			
		O					DRAWING NO.			

标记 SYM.	处数 No.	设计变更内容 DESCRIPTION REVISIONS	签名 Name	日期 DATE
▲				

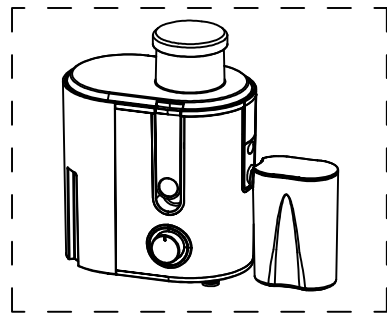
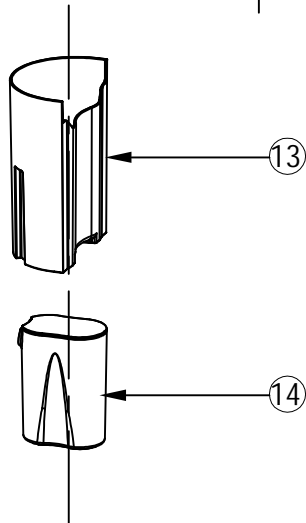
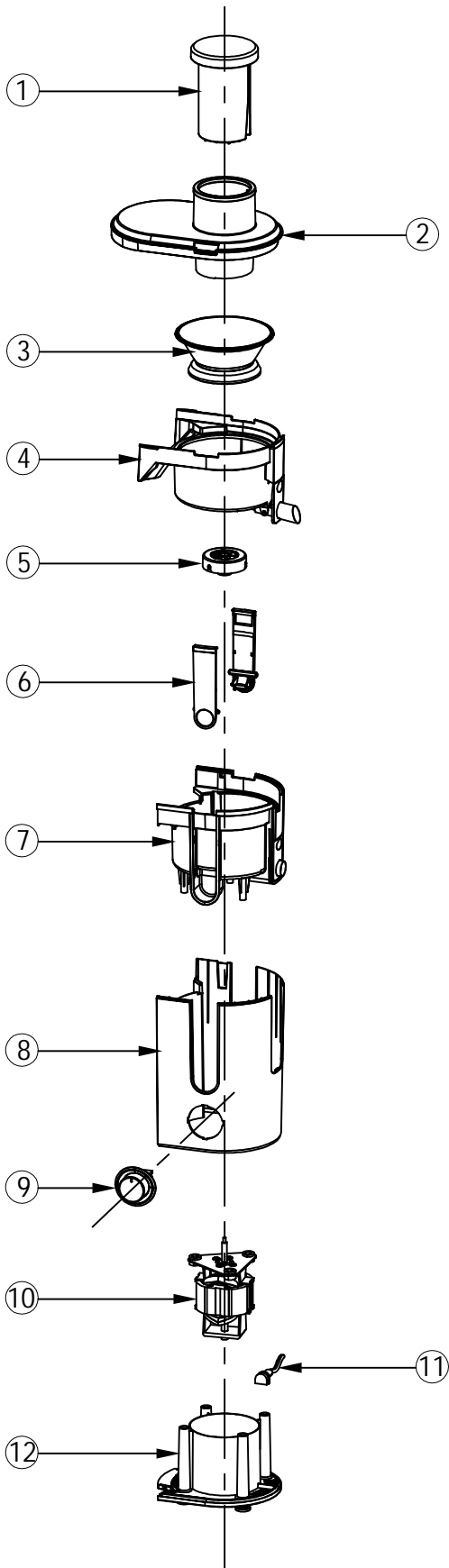

⑭	322接汁杯 juice cup		1	
⑬	338接渣桶 residue collector		1	
⑫	338底座组件 bottom		1	
⑪	301电源线 power cord		1	
⑩	电机组件 motor		1	
⑨	336旋钮组件 rotation switch set		1	
⑧	339外壳组件 housing		1	
⑦	339电机座组件 motor base		1	
⑥	339扣手组件 handle set		1	
⑤	330转座 gear		1	
④	338接汁盘半成品 middle layer set		1	
③	338榨汁网半成品 extract filter		1	
②	339面盖组件 top cover		1	
①	310推果棒 pusher		1	
序号 NO.	物料名称 name	规格及型号 specification	用量 QTY	备注 remark

钟富成	MATERIAL	FINISHING	3RD ANGLE'S	比例 SCALE	1/1	单位 UNIT	m/m
2017. 12. 18	±0.2 M/M		± 度	DESCRIPTION	爆炸图	版次 REV.	▲A1
邱文浩	TOLERANCES	OTHERWISE	SPECIFIC	MODEL NO.			共 1 页
2017. 12. 20			ANGULAR	DRAWING NO.			第 1 页