

# **Service Manual**

**PIA 9064A/65B**

**PIA 9066A/67B**

**PIA 12064A/65B**

**PIA 12066A/67B**

**PIA 18064A/18065B**

**PIA 18066A/18067B**

# Content

<b>1. Precaution</b>	<b>2</b>
<b>1.1 Safety Precaution</b>	<b>2</b>
<b>1.2 Warning</b>	<b>2</b>
<b>2. Function</b>	<b>4</b>
<b>3. Dimension</b>	<b>6</b>
<b>3.1 Indoor unit</b>	<b>6</b>
<b>3.2 Outdoor unit</b>	<b>6</b>
<b>4. Refrigerant cycle diagram</b>	<b>11</b>
<b>5. Operation limits</b>	<b>12</b>
<b>5.1 Cooling operation</b>	<b>12</b>
<b>5.2 Heating operation</b>	<b>12</b>
<b>6. Wiring diagram</b>	<b>14</b>
<b>7. Installation details</b>	<b>21</b>
<b>7.1 Wrench torque sheet for installation</b>	<b>21</b>
<b>7.2 Connecting the cables</b>	<b>21</b>
<b>7.3 Pipe length and the elevation</b>	<b>21</b>
<b>7.4 Air purging of the piping and indoor unit</b>	<b>23</b>
<b>7.5 Pumping down (Re-installation)</b>	<b>24</b>
<b>7.6 Re-air purging (Re-installation)</b>	<b>25</b>
<b>7.7 Balance refrigerant of the 2-way, 3-way valves</b>	<b>26</b>
<b>7.8 Evacuation</b>	<b>27</b>
<b>7.9 Gas charging</b>	<b>28</b>
<b>8. Electronic function</b>	<b>29</b>
<b>8.1 Proper symbols and their meaning</b>	<b>29</b>
<b>8.2 Function</b>	<b>29</b>
<b>8.3 Protection</b>	<b>29</b>
<b>8.4 Fan-only mode</b>	<b>30</b>
<b>8.5 Cooling mode</b>	<b>30</b>
<b>8.6 Dehumidifying mode</b>	<b>31</b>
<b>8.7 Heating mode</b>	<b>32</b>
<b>8.8 Defrosting mode (available for heating mode)</b>	<b>33</b>
<b>8.9 Auto mode</b>	<b>34</b>
<b>8.10 Force cooling function</b>	<b>35</b>
<b>8.11 Sleep mode</b>	<b>35</b>
<b>8.12 Auto restart function</b>	<b>35</b>
<b>8.13 Turbo mode</b>	<b>35</b>
<b>9. Model and Parameters</b>	<b>36</b>

<b>10. Troubleshooting</b>	<b>37</b>
<b>10.1 Display board</b>	<b>37</b>
<b>10.2 Troubleshooting</b>	<b>37</b>
<b>10.3 Diagnostic chart</b>	<b>38</b>
<b>10.4 Resetting phenomenon often occurs during operation.</b>	<b>39</b>
<b>10.5 Operation lamp flashes and Timer lamp off.</b>	<b>39</b>
<b>10.6 Operation lamp flashes and Timer lamp on.</b>	<b>39</b>
<b>10.7 Operation lamp off and Timer lamp flashes</b>	<b>40</b>
<b>10.8 Operation lamp on and Timer lamp flashes</b>	<b>40</b>
<b>10.9 Operation lamp flashes, Timer lamp flashes .</b>	<b>40</b>
<b>11. Characteristic of temperature sensor</b>	<b>41</b>

## 1. Precaution

### 1.1 Safety Precaution

- To prevent injury to the user or other people and property damage, the following instructions must be followed.
- Incorrect operation due to ignoring instruction will cause harm or damage.
- Before service unit, be sure to read this service manual at first.

### 1.2 Warning

#### ➤ Installation

- Do not use a defective or underrated circuit breaker. Use this appliance on a dedicated circuit.  
There is risk of fire or electric shock.
  - For electrical work, contact the dealer, seller, a qualified electrician, or an Authorized service center.  
Do not disassemble or repair the product, there is risk of fire or electric shock.
  - Always ground the product.  
There is risk of fire or electric shock.
  - Install the panel and the cover of control box securely.  
There is risk of fire of electric shock.
  - Always install a dedicated circuit and breaker.  
Improper wiring or installation may cause fore or electric shock.
  - Use the correctly rated breaker of fuse.  
There is risk of fire or electric shock.
  - Do not modify or extend the power cable.  
There is risk of fire or electric shock.
  - Do not install, remove, or reinstall the unit by yourself (customer).  
There is risk of fire, electric shock, explosion, or injury.
  - Be caution when unpacking and installing the product.  
Sharp edges could cause injury, be especially careful of the case edges and the fins on the condenser and evaporator.
  - For installation, always contact the dealer or an Authorized service center.  
There is risk of fire, electric shock, explosion, or injury.
  - Do not install the product on a defective installation stand.  
It may cause injury, accident, or damage to the product.
  - Be sure the installation area does not deteriorate with age.
- If the base collapses, the air conditioner could fall with it, causing property damage, product failure, and personal injury.
- Do not let the air conditioner run for a long time when the humidity is very high and a door or a windows is left open.  
Moisture may condense and wet or damage furniture.
  - Take care to ensure that power cable could not be pulled out or damaged during operation.  
There is risk of fire or electric shock.
  - Do not place anything on the power cable.  
There is risk of fire or electric shock.
  - Do not plug or unplug the power supply plug during operation.  
There is risk of fire or electric shock.
  - Do not touch (operation) the product with wet hands.  
There is risk of fire or electric shock.
  - Do not place a heater or other appliance near the power cable.  
There is risk of fire and electric shock.
  - Do not allow water to run into electric parts.  
It may cause fire, failure of the product, or electric shock.
  - Do not store or use flammable gas or combustible near the product.  
There is risk of fire or failure of product.
  - Do not use the product in a tightly closed space for a long time.  
Oxygen deficiency could occur.
  - When flammable gas leaks, turn off the gas and open a window for ventilation before turn the product on.  
Do not use the telephone or turn switches on or off.  
There is risk of explosion or fire.
  - If strange sounds, or small or smoke comes from product. Turn the breaker off or disconnect the power supply cable.  
There is risk of electric shock or fire.

- **Stop operation and close the window in storm or hurricane. If possible, remove the product from the window before the hurricane arrives.**  
There is risk of property damage, failure of product, or electric shock.
- **Do not open the inlet grill of the product during operation. (Do not touch the electrostatic filter, if the unit is so equipped.)**  
There is risk of physical injury, electric shock, or product failure.
- **When the product is soaked (flooded or submerged), contact an Authorized service center.**  
There is risk of fire or electric shock.
- **Be caution that water could not enter the product.**  
There is risk of fire, electric shock, or product damage.
- **Ventilate the product from time to time when operating it together with a stove, etc.**  
There is risk of fire or electric shock.
- **Turn the main power off when cleaning or maintaining the product.**  
There is risk of electric shock.
- **When the product is not be used for a long time, disconnect the power supply plug or turn off the breaker.**  
There is risk of product damage or failure, or unintended operation.
- **Take care to ensure that nobody could step on or fall onto the outdoor unit.**  
This could result in personal injury and product damage.

➤ **CAUTION**

- **Always check for gas (refrigerant) leakage after installation or repair of product.**  
Low refrigerant levels may cause failure of product.
- **Install the drain hose to ensure that water is drained away properly.**  
A bad connection may cause water leakage.
- **Keep level even when installing the product.**  
To avoid vibration of water leakage.
- **Do not install the product where the noise or hot air from the outdoor unit could damage the neighborhoods.**  
It may cause a problem for your neighbors.
- **Use two or more people to lift and transport the product.**

Avoid personal injury.

- **Do not install the product where it will be exposed to sea wind (salt spray) directly.**  
It may cause corrosion on the product. Corrosion, particularly on the condenser and evaporator fins, could cause product malfunction or inefficient operation.

➤ Operational

- **Do not expose the skin directly to cool air for long periods of time. (Do not sit in the draft).**  
This could harm to your health.
- **Do not use the product for special purposes, such as preserving foods, works of art, etc. It is a consumer air conditioner, not a precision refrigerant system.**  
There is risk of damage or loss of property.
- **Do not block the inlet or outlet of air flow.**  
It may cause product failure.
- **Use a soft cloth to clean. Do not use harsh detergents, solvents, etc.**  
There is risk of fire, electric shock, or damage to the plastic parts of the product.
- **Do not touch the metal parts of the product when removing the air filter. They are very sharp.**  
There is risk of personal injury.
- **Do not step on or put anything on the product. (outdoor units)**  
There is risk of personal injury and failure of product.
- **Always insert the filter securely. Clean the filter every two weeks or more often if necessary.**  
A dirty filter reduces the efficiency of the air

conditioner and could cause product malfunction or damage.

- **Do not insert hands or other object through air inlet or outlet while the product is operated.**  
There are sharp and moving parts that could cause personal injury.
- **Do not drink the water drained from the product.**  
It is not sanitary could cause serious health issues.
- **Use a firm stool or ladder when cleaning or maintaining the product.**  
Be careful and avoid personal injury.
- **Replace the all batteries in the remote control with new ones of the same type. Do not mix old and new batteries or different types of batteries.**  
There is risk of fire or explosion.
- **Do not recharge or disassemble the batteries. Do not dispose of batteries in a fire.**  
They may burn or explode.
- **If the liquid from the batteries gets onto your skin or clothes, wash it well with clean water. Do not use the remote of the batteries have leaked.**  
The chemical in batteries could cause burns or other health hazards.

## 2. Function

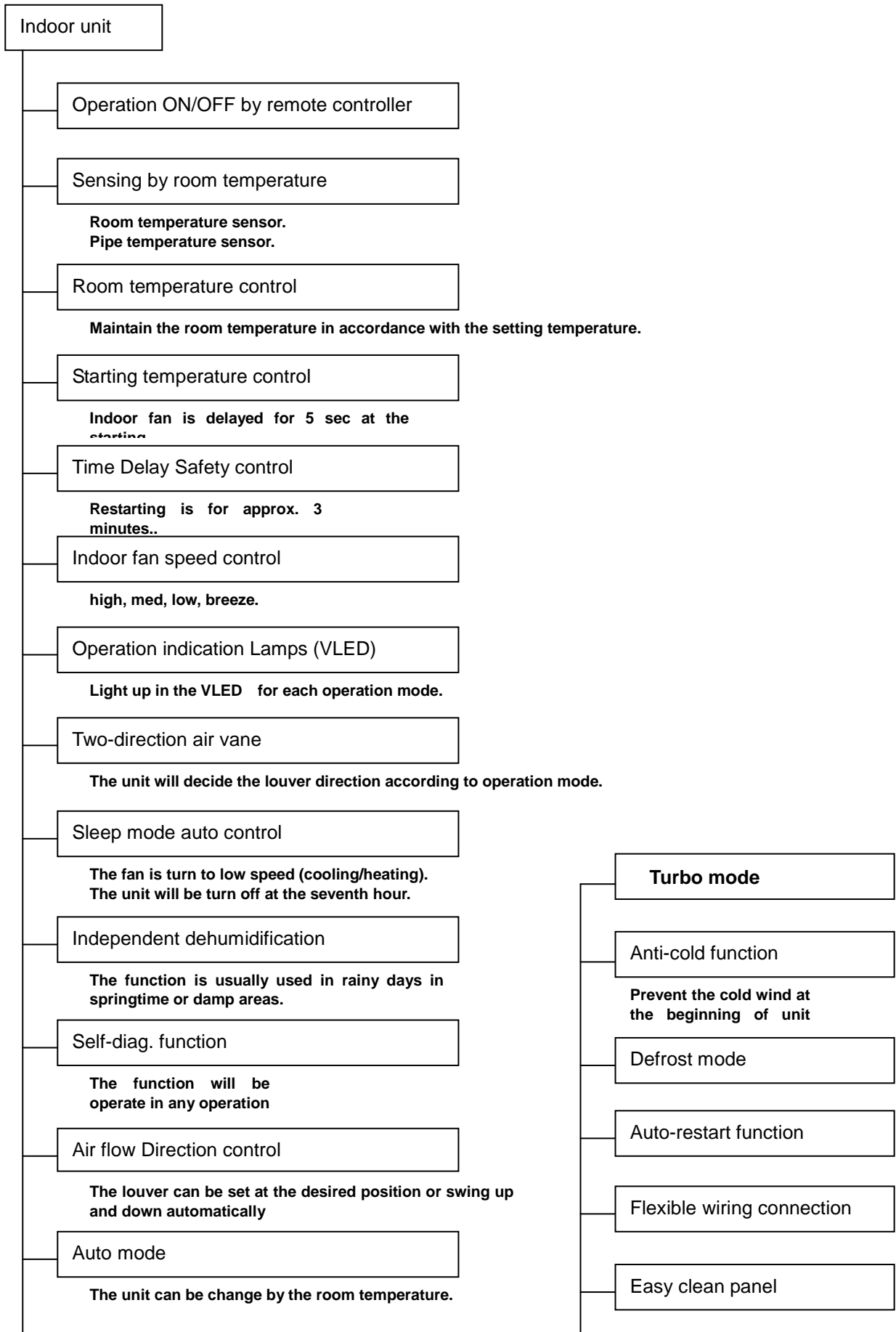

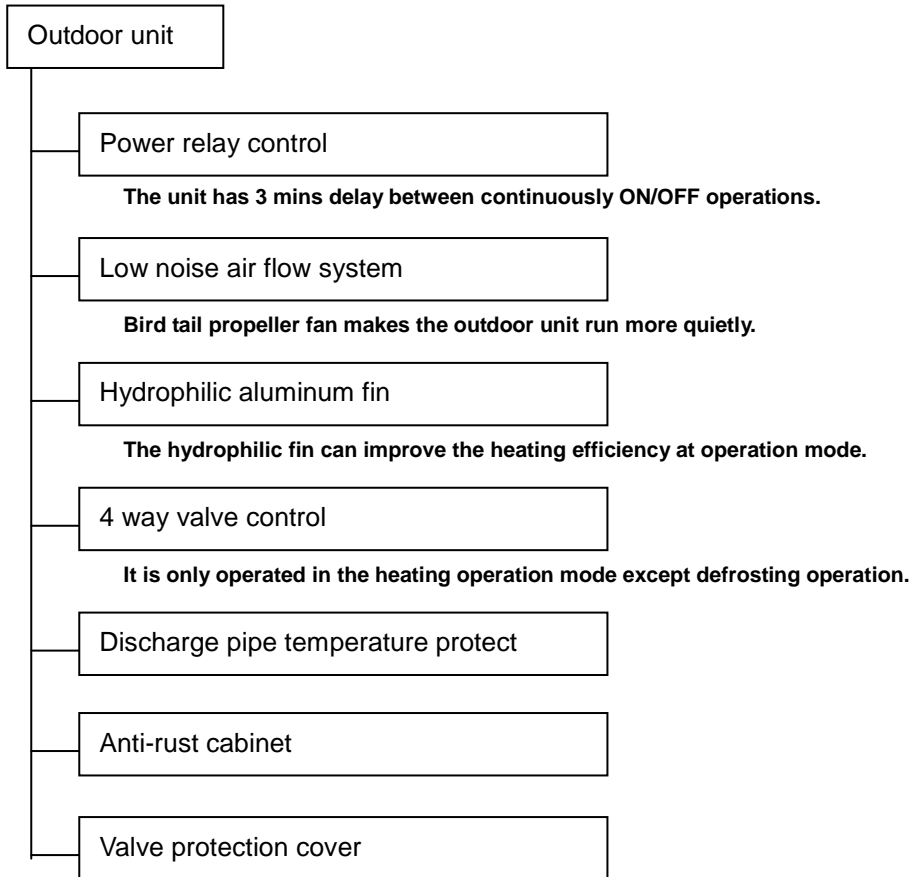



### 3. Dimension

#### 3.1 Indoor unit

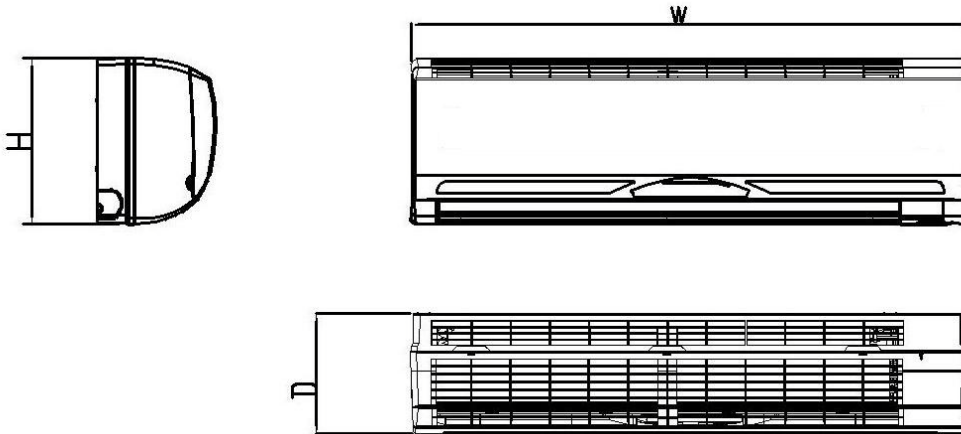

#### 1.3

Dimension Mode	W	H	D
7/9/12K	790	275	195
18K	928	275	195

#### 3.2 Outdoor unit

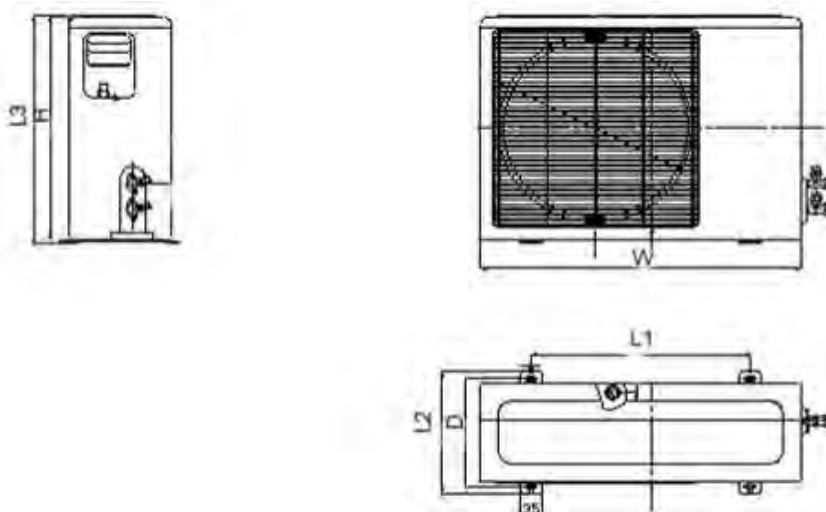

Dimension Mode	W	H	D	L1	L2	L3
7K(B4)	685	430	276	460	300	445
9K(B4)	685	430	276	460	300	445
9K(B6)	700	522	250	458	275	537
12K(B4)	700	522	250	458	275	537
12K(B6)	780	540	266	549	290	555
18K(B4)	780	540	266	549	290	555

**Specification :**

Model			MSR-07CR	MSR-07HR	MSR-09CR	MSR-09HR
Power supply		Ph-V-Hz	1Ph, 220-230V~, 60Hz	1Ph, 220-230V~, 60Hz	1Ph, 220-230V~, 60Hz	1Ph, 220-230V~, 60Hz
Cooling	Capacity	Btu/h	7000	7000	9000	9000
	Input	W	800	800	1000	1000
	Rated current	A	3.7	3.7	4.6	4.6
	EER	Btu/w.h	8.75	8.75	8.5	8.5
Heating	Capacity	Btu/h	—	7000	—	9000
	Input	W	—	680	—	850
	Rated current	A	—	3.1	—	3.9
	COP	Btu/w.h	—	10.3	—	10.6
Max. input consumption		W	950	950	1200	1200
Max. current		A	4.2	4.2	5.8	5.8
Starting current		A	17	17	22	22
Compressor	Model		39R172BS-530	39R172BS-530	44R232AE-FJS	44R232AE-FJS
	Type		Rotary	Rotary	Rotary	Rotary
	Brand		RECHI	RECHI	RECHI	RECHI
	Capacity	Btu/h	6107	6107	7677	7677
	Input	W	700	700	840	840
	Rated current(RLA)	A	3.1	3.1	3.8	3.8
	Locked rotor Amp	A	17	17	22	22
	Thermal protector		MAR12090-9054	MAR12090-9054	TongbaoB175-145B-141C	TongbaoB175-145B-141C
	Capacitor	μF	20μF/370V	20μF/370V	25μF/370V	25μF/370V
	Refrigerant oil	ml	210	210	270	270
Indoor fan m	Model		RPG13M	RPG13M	RPG13M	RPG13M
	Brand		Welling	Welling	Welling	Welling
	Input	W	35W/1520RPM	35W/1520RPM	35W/1520RPM	35W/1520RPM
	Capacitor	μF	1.5μF/450V	1.5UF/450V	1.5μF/450V	1.5μF/450V
	Speed(hi/mi/lo)	r/min	1050/900/800	1050/900/800	1150/1000/850	1150/1000/850
Indoor air flow (Hi/Mi/Lo)		m3/h	370/317/282	370/317/282	430/373/318	430/373/318
Indoor noise level (Hi/Mi/Lo)		dB(A)	39/36/32	39/36/32	40/37/33	40/37/33
Indoor unit	Dimension (WxHxD)	mm	790x275x190	790x275x190	790x275x190	790x275x190
	Packing (WxHxD)	mm	865x350x265	865x350x265	865x350x265	865x350x265
	Net/Gross weight	Kg	8.5/10.5	8.5/10.5	8.5/10.5	8.5/10.5
Outdoor fan	Model		YDK23-4B	YDK23-4B	YDK23-4B	YDK23-4B
	Brand		DY	DY	DY	DY
	Input	W	62	62	62	62
	Capacitor	μF	2.0μF/450V	2.0μF/450V	2.0μF/450V	2.0μF/450V
	Speed	r/min	950	950	950	950
Outdoor air flow		m3/h	1250	1250	1250	1250
Outdoor noise level		dB(A)	52	52	54	54
Outdoor unit	Dimension(WxHxD)	mm	685x430x260	685x430x260	685x430x260	685x430x260
	Packing (WxHxD)	mm	795x495x345	795x495x346	795x495x347	795x495x348
	Net/Gross weight	Kg	21/24	22/25	24/27	25/28
Refrigerant type		g	R22/500	R22/530	R22/560	R22/560
Design pressure		MPa	2.6	2.6	2.6	2.6
Refrigerant p	Liquid side/ Gas si	mm(inch)	Φ6.35/Φ9.53	Φ6.35/Φ9.53	Φ6.35/Φ9.53	Φ6.35/Φ9.53
	Max. refrigerant pi	m	10	10	10	10
	Max. difference in	m	5	5	5	5
Operation temp		°C	17-30	17-30	17-30	17-30
Ambient temp		°C	18-45	-7-45	18- 45	-7-45
Application area		m2	10-14	10-14	14-20	14-20

**Note:**

•The noise date is base on hemi-anechoic chamber during actual operation, these values are normally somewhat different as a result

## Service manual

of ambient condition.

▪The above design and specifications are subject to change without prior notice for product improvement.

Model		MSR-09CR	MSR-09HR	MSR-12CR	MSR-12HR
Power supply		Ph-V-Hz	1Ph, 220-230V~, 60Hz	1Ph, 220-230V~, 60Hz	1Ph, 220-230V~, 60Hz
Cooling	Capacity	Btu/h	9000	9000	12000
	Input	W	1050	1050	1350
	Rated current	A	4.6	4.6	6.2
	EER	Btu/w.h	8.6	8.6	8.2
Heating	Capacity	Btu/h	—	10000	—
	Input	W	—	1020	—
	Rated current	A	—	4.45	—
	COP	Btu/w.h	—	2.88	—
Max. input consumption		W	1300	1300	1650
Max. current		A	6.3	6.3	8.8
Starting current		A	26	26	30
Compressor	Model		2P15S236A1E	2P15S236AIE	44R312AG-FJSC
	Type		Rotary	Rotary	Rotary
	Brand		GD MATSUSHITA	GD MATSUSHITA	RECHI
	Capacity	Btu/h	10130	10130	10782
	Input	W	930	930	1185
	Rated current(RLA)	A	4.1	4.1	5.3
	Locked rotor Amp	A	26	26	30
	Thermal protector		MRA99027	MRA99027	TongbaoB245-140B-141H
	Capacitor	μF	30μF/330V	30μF/330V	30μF/370V
Refrigerant oil	ml	270	270	270	
Indoor fan m	Model		RPG13M	RPG13M	RPG13M
	Brand		Welling	Welling	Welling
	Input	W	35W/1520RPM	35W/1520RPM	35W/1520RPM
	Capacitor	μF	1.5μF/450V	1.5μF/450V	1.5μF/450V
	Speed(hi/mi/lo)	r/min	1250/1100/850	1250/1100/850	1220/1100/850
Indoor air flow (Hi/Mi/Lo)		m3/h	450/400/350	450/400/350	480/432/335
Indoor noise level (Hi/Mi/Lo)		dB(A)	39/36/32	39/36/32	43/41/33
Indoor unit	Dimension (WxHxD)	mm	790x275x190	790x275x190	790x275x190
	Packing (WxHxD)	mm	865x350x265	865x350x265	865x350x265
	Net/Gross weight	Kg	8.5/10.5	8.5/10.5	9/11
Outdoor fan	Model		YDK30-6B	YDK30-6B	YDK30-6B
	Brand		Welling	Welling	Welling
	Input	W	72	72	72
	Capacitor	μF	2.5μF/450V	2.5μF/450V	2.5μF/450V
	Speed	r/min	860	860	860
Outdoor air flow		m3/h	1800	1800	1500
Outdoor noise level		dB(A)	53	53	57
Outdoor unit	Dimension(WxHxD)	mm	700x535x250	700x535x250	700x535x250
	Packing (WxHxD)	mm	815x580x325	815x580x325	815x580x325
	Net/Gross weight	Kg	28/31	28/31	27/29
Refrigerant type		g	R22/580	R22/700	R22/650
Design pressure		MPa	2.6	2.6	2.6
Refrigerant p	Liquid side/ Gas si	mm(inch)	Φ6.35/Φ9.53	Φ6.35/Φ9.53	Φ6.35/Φ12.7
	Max. refrigerant pip	m	10	10	10
	Max. difference in	m	5	5	5
Operation temp		°C	17-30	17-30	17~30
Ambient temp		°C	18-45	-7 - 45	18~ 45
Application area		m2	14~20	14~20	18~24

### Note:

▪The noise date is base on hemi-anechoic chamber during actual operation, these values are normally somewhat different as a result of ambient condition.

## Service manual

▪The above design and specifications are subject to change without prior notice for product improvement.

Model		MSR-12CR	MSR-12HR	MSR-18CR	MSR-18HR	
Power supply		Ph-V-Hz	1Ph, 220-230V~, 60Hz	1Ph, 220-230V~, 60Hz	1Ph, 220-230V~, 60Hz	1Ph, 220-230V~, 60Hz
Cooling	Capacity	Btu/h	12000	12000	18000	18000
	Input	W	1330	1330	1700	1700
	Rated current	A	6.1	6.1	8.7	8.7
	EER	Btu/w.h	9	9	9.4	9.4
Heating	Capacity	Btu/h	—	14000	—	17500
	Input	W	—	1400	—	17500
	Rated current	A	—	6.4	—	8.2
	COP	Btu/w.h	—	2.93	—	3.0
Max. input consumption		W	1700	1700	2200	2200
Max. current		A	8	8.5	10	10
Starting current		A	32	32	40	40
Compressor	Model		PH195x2C-3FTU1	PH195x2C-3FTU1	PH240x2C-3FTU1	PH240x2C-3FTU1
	Type		Rotary	Rotary	Rotary	Rotary
	Brand		GD TOSHIBA	GD TOSHIBA	GD TOSHIBA	GD TOSHIBA
	Capacity	Btu/h	13716	13716	17500	17500
	Input	W	1325	1325	1655	1655
	Rated current(RLA)	A	5.8	5.8	7.26	7.26
	Locked rotor Amp	A	32	32	40	40
	Thermal protector		UP3QE0591-T36	UP3QE0591-T36	UP3QE0591-T39	UP3QE0591-T39
	Capacitor	μF	40μF/370V	40μF/370V	40μF/370V	40μF/370V
Refrigerant oil	ml	480	480	480	480	
Indoor fan m	Model		RPG13M	RPG13M	RPG28E	RPG28E
	Brand		Welling	Welling	Welling	Welling
	Input	W	35W/1520RPM	35W/1520RPM	55W/1180RPM	55W/1180RPM
	Capacitor	μF	1.5μF/450V	1.5μF/450V	1.5UF/450V	1.5UF/450V
	Speed(hi/mi/lo)	r/min	1180/1000/850	1180/1000/850	1220/1100/850	1220/1100/850
Indoor air flow (Hi/Mi/Lo)		m3/h	580/500/420	580/500/420	780/703/550	780/703/550
Indoor noise level (Hi/Mi/Lo)		dB(A)	40/35/30	40/35/30	44.8/42.6/36	44.8/42.6/36
Indoor unit	Dimension (WxHxD)	mm	790x275x190	790x275x190	928x198x275	928x198x275
	Packing (WxHxD)	mm	865x350x265	865x350x265	1015x265x350	1015x265x350
	Net/Gross weight	Kg	9.0/11.0	9.0/11.0	10/13.5	10/13.5
Outdoor fan	Model		YDK25-6B	YDK25-6B	YDK36-6B	YDK36-6B
	Brand		Welling	Welling	Welling	Welling
	Input	W	82.5	82.5	85	85
	Capacitor	μF	2.5μF/450V	2.5μF/450V	2.5μF/450V	2.5μF/450V
	Speed	r/min	960	960	930	930
Outdoor air flow		m3/h	2000	2000	2000	2000
Outdoor noise level		dB(A)	54	54	58	58
Outdoor unit	Dimension(WxHxD)	mm	780x540x250	780x540x250	780x540x250	780x540x250
	Packing (WxHxD)	mm	910x575x335	910x575x335	910x335x575	910x335x575
	Net/Gross weight	Kg	34/37	34/37	34/37	35/38
Refrigerant type		g	R22/700	R22/900	R22/1150	R22/1280
Design pressure		MPa	2.6	2.6	2.6	2.6
Refrigerant p	Liquid side/ Gas si	mm(inch)	Φ6.35/Φ12.7	Φ6.35/Φ12.7	Φ6.35/Φ12.7	Φ6.35/Φ12.7
	Max. refrigerant pi	m	10	10	15	15
	Max. difference in	m	5	5	8	8
Operation temp		°C	17-30	17-30	17~30	17~30
Ambient temp		°C	18-45	-7 - 45	18~ 45	-7~45
Application area		m2	18~26	18~26	26~35	26~35

### Note:

▪The noise date is base on hemi-anechoic chamber during actual operation, these values are normally somewhat different as a result of ambient condition.

▪The above design and specifications are subject to change without prior notice for product improvement.

▪

#### 4. Refrigerant cycle diagram

➤ Cooling only

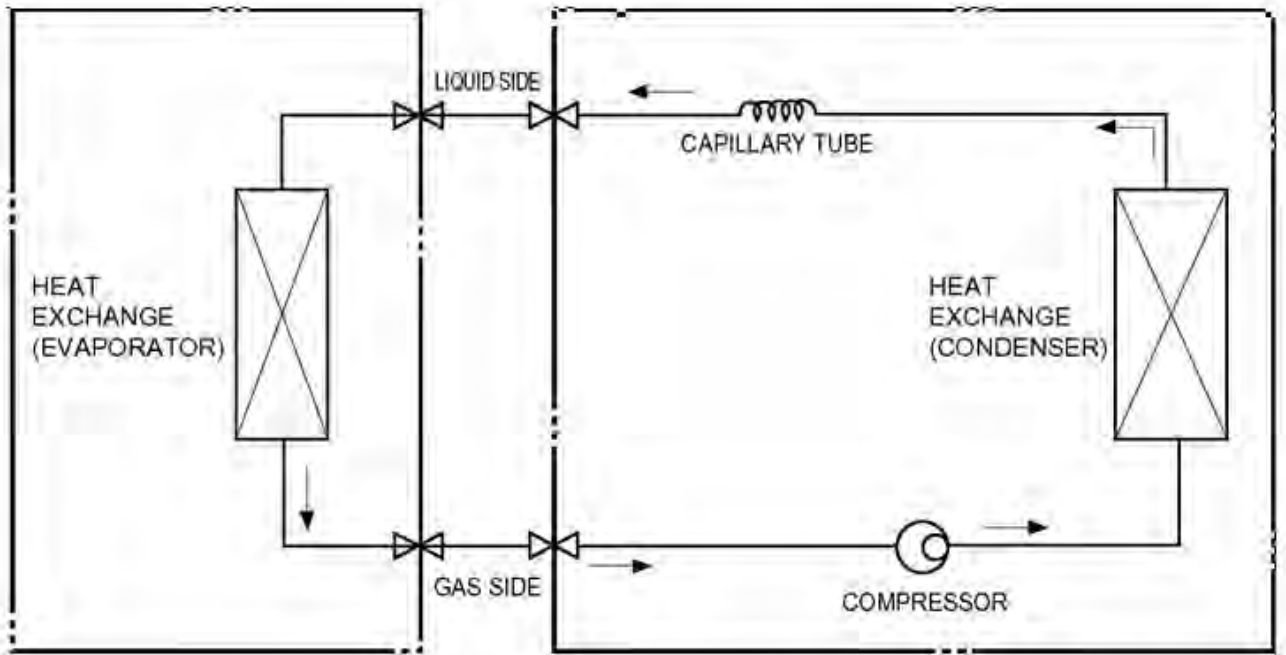

➤ Heat pump mode

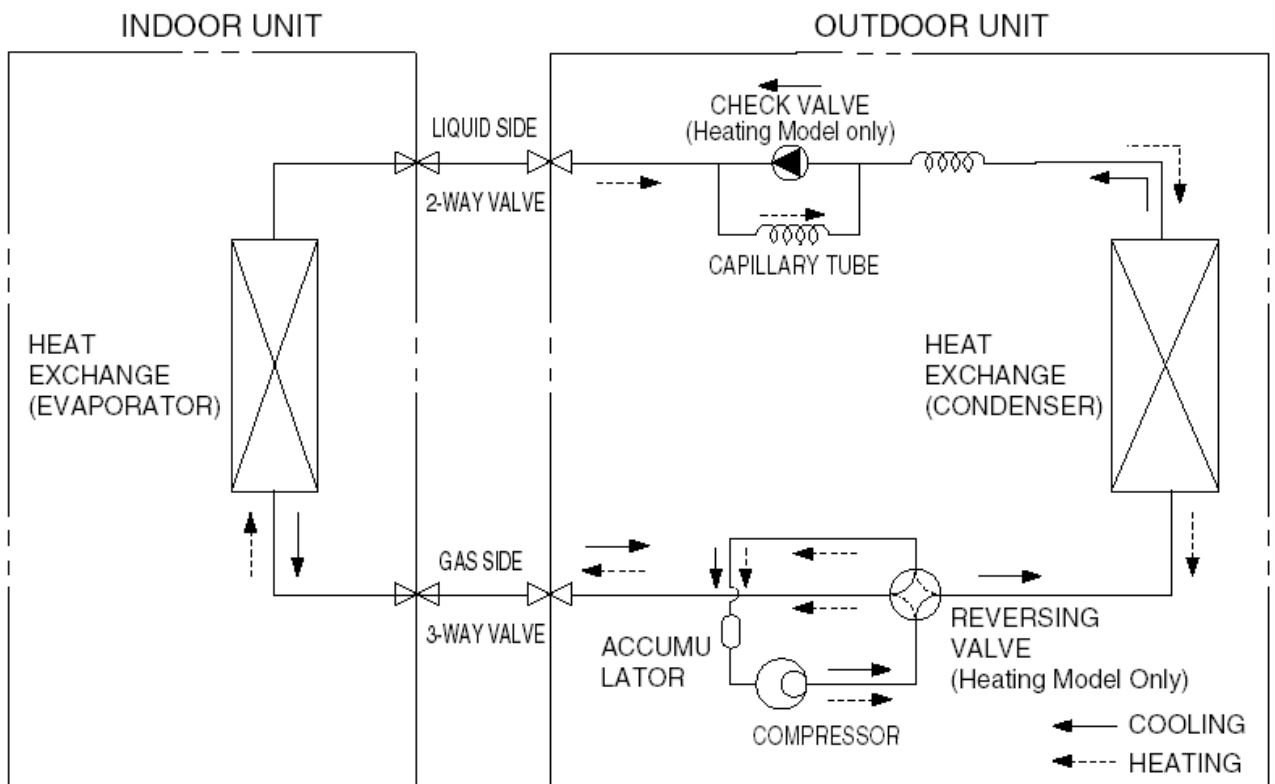

## 5. Operation limits

### 5.1 Cooling operation

Outdoor unit air temp. °C DB

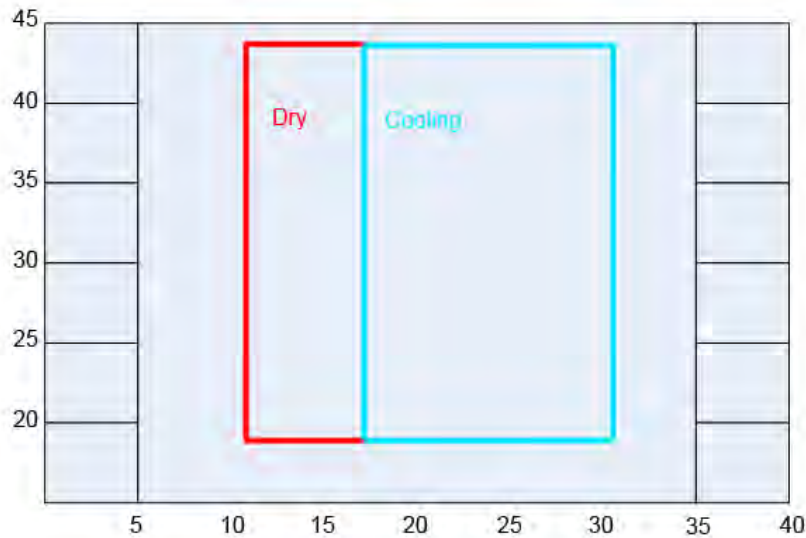

Indoor air temp. °C DB

**Note:** The chart is the result from the continuous operation under constant air temperature conditions. However, excludes the initial pull-down stage.

### 5.2 Heating operation

Indoor air temp. °C DB

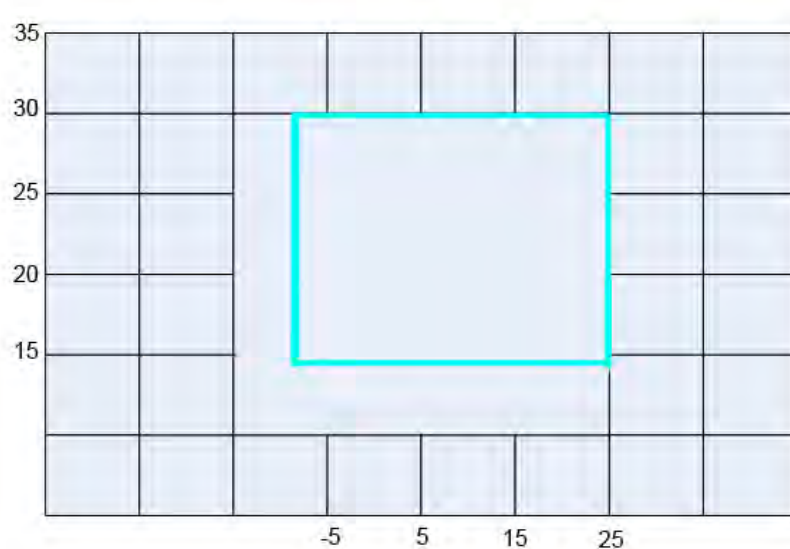

Outdoor unit air temp. °C DB

**Note:** The chart is the result from the continuous operation under constant air temperature conditions. However, excludes the initial pull-down stage.





## 6. Wiring diagram

Indoor :

MSR-07CR-NB4

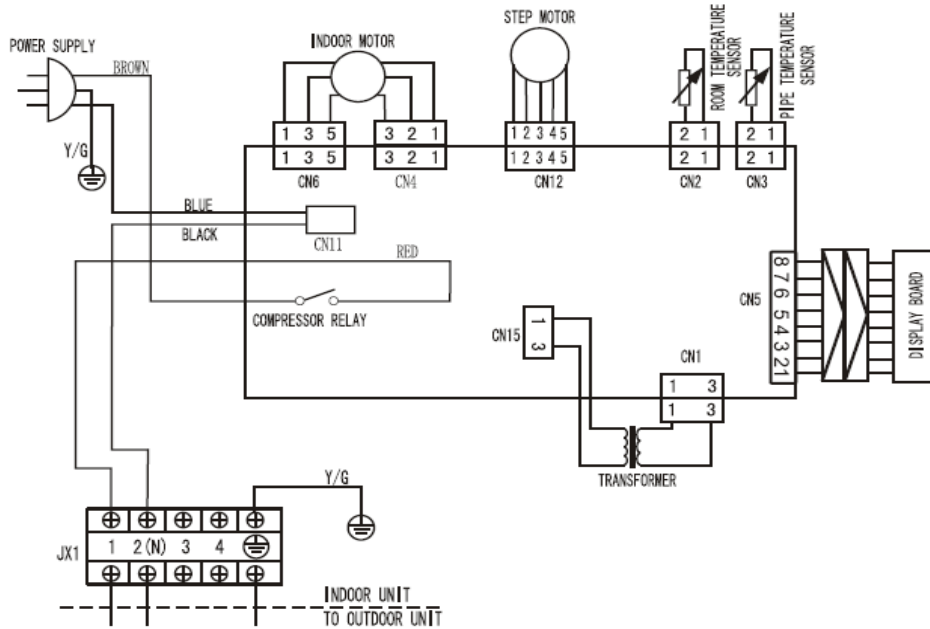

Outdoor :

MSR-07CR-NB4 , MSR-09CR-NB4

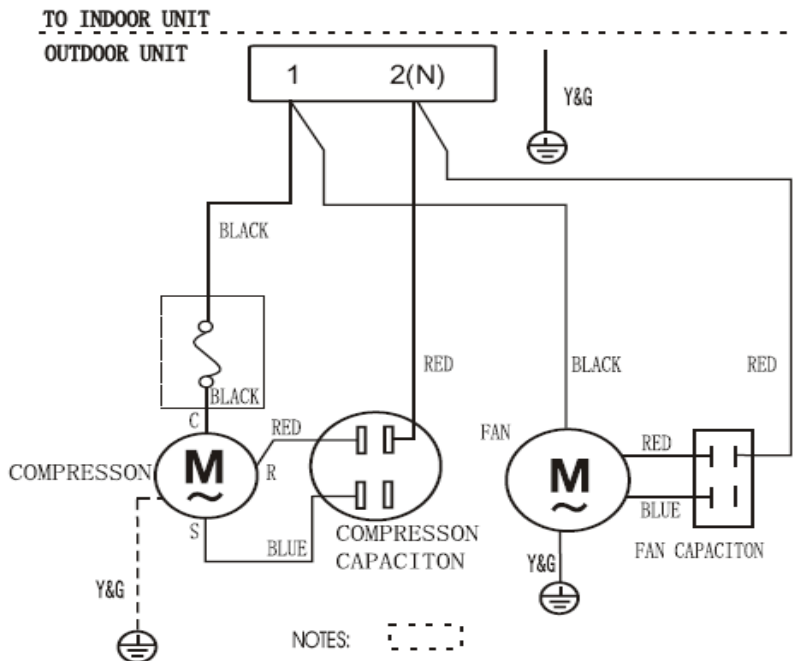

NOTES:

This symbol indicates the element is optional, the actual shape shall prevail.

Indoor :

**MSR-09CR-NB4 , MSR-12CR-NB4 , MSR-12CR-NB6**

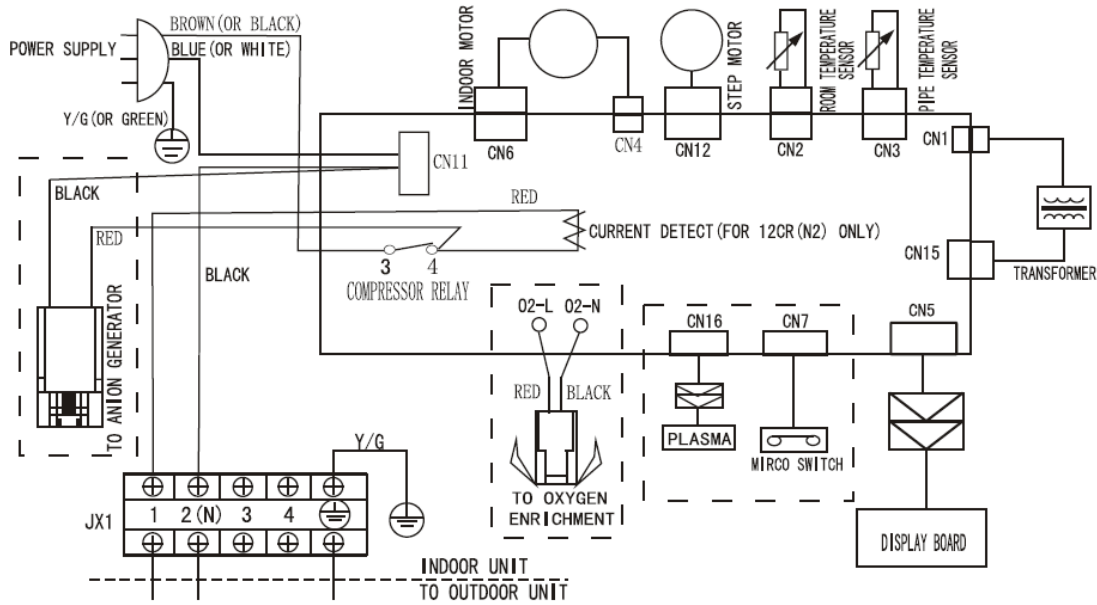

**NOTES:**

1. The Color Of Power Supply Cord(L, N, E) Measures Up To The IEC Standards (BROWN, BIUE, Y/G) Or The UL Standards (BLACK, WHITE, GREEN) ;
2. The Functions In The Rectangle Are Available For Particular Air-condition;

Indoor :

**MSR-09CR-NB6**

**Service manual**

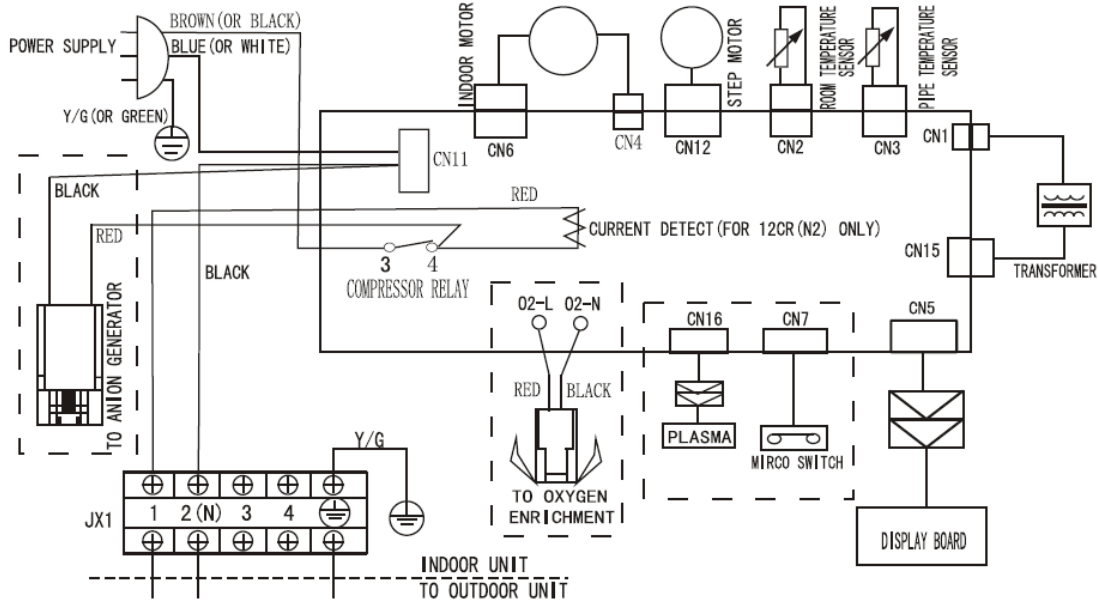

**NOTES:**

1. The Color Of Power Supply Cord(L, N, E) Measures Up To The IEC Standards (BROWN, BLUE, Y/G) Or The UL Standards (BLACK, WHITE, GREEN) ;
2. The Functions In The Rectangle Are Available For Particular Air-condition;

**Outdoor :**

**MSR-09CR-NB6 , MSR-12CR-NB4 , MSR-12CR-NB6**

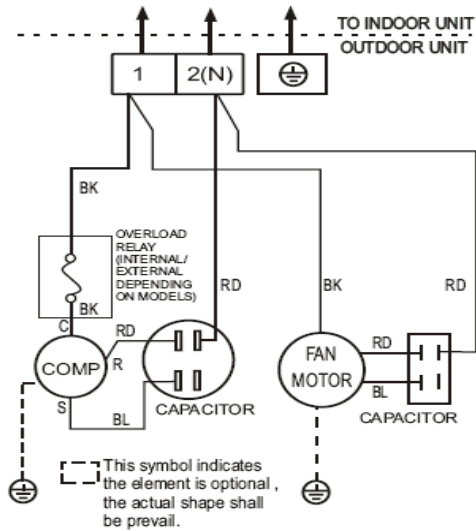

**Indoor:**

**MSR-09HR-NB4 , MSR-09HR-NB6 , MSR-12HR-NB4 , MSR-12HR-NB6**

**Service manual**

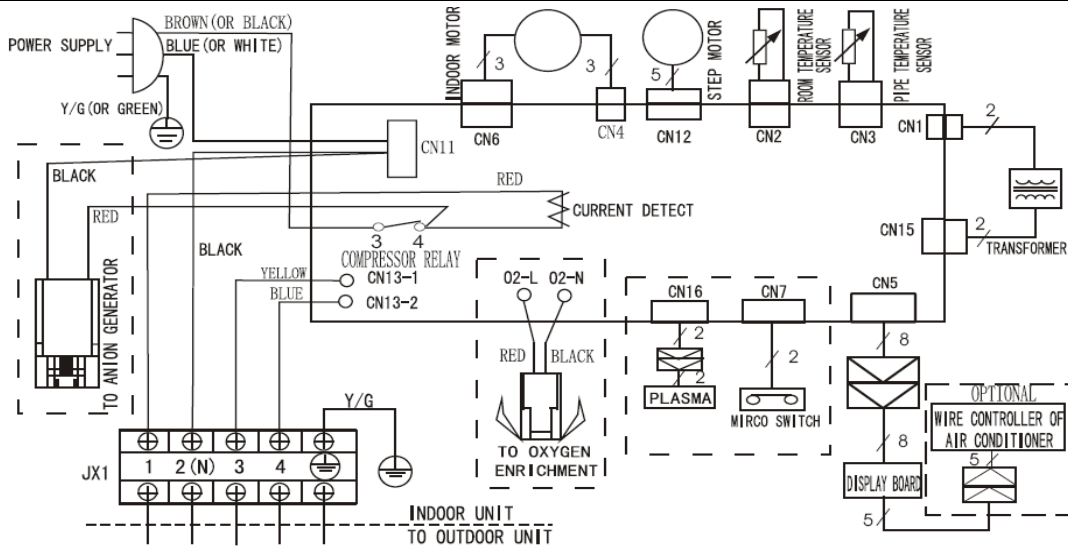

**NOTES:**

1. The Color Of Power Supply Cord(L, N, E) Measures Up To The IEC Standards (BROWN, BIUE, Y/G) Or The UL Standards (BLACK, WHITE, GREEN) ;
2. The Functions In The Rectangle Are Available For Particular Air-condition;

**Indoor :**

**MSR-07HR-NB4**

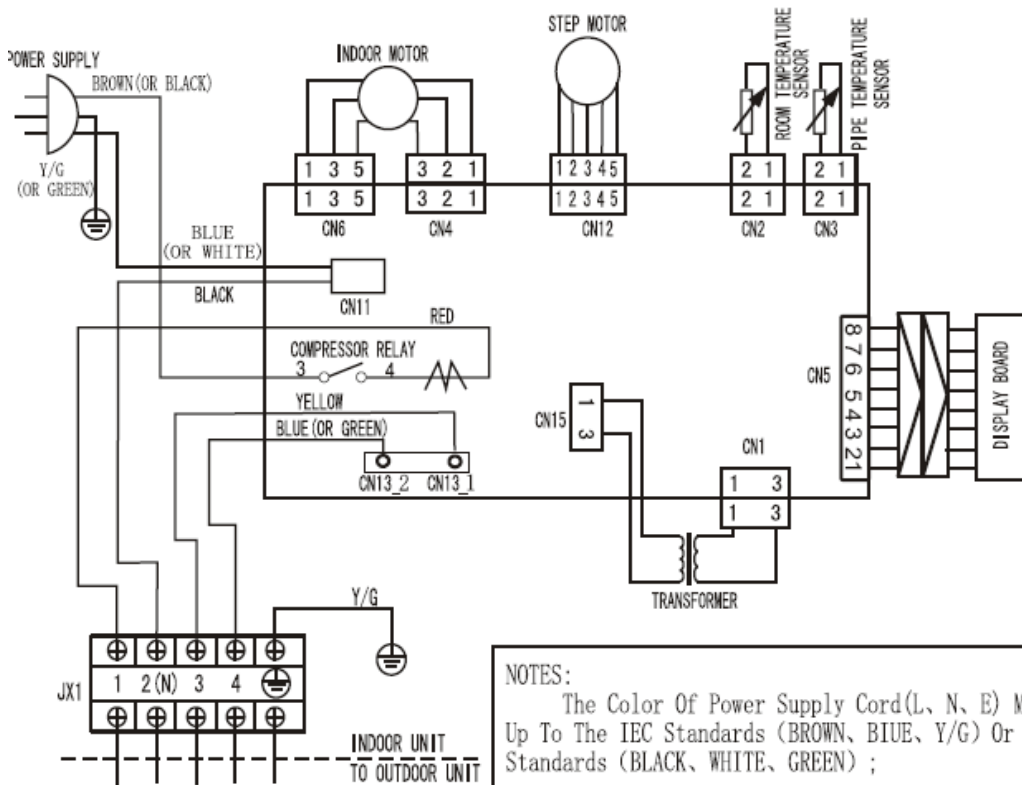

**NOTES:**

- The Color Of Power Supply Cord(L, N, E) Measures Up To The IEC Standards (BROWN, BIUE, Y/G) Or The UL Standards (BLACK, WHITE, GREEN) ;

**Outdoor :**

**MSR-07HR-NB4 , MSR-09HR-NB4**

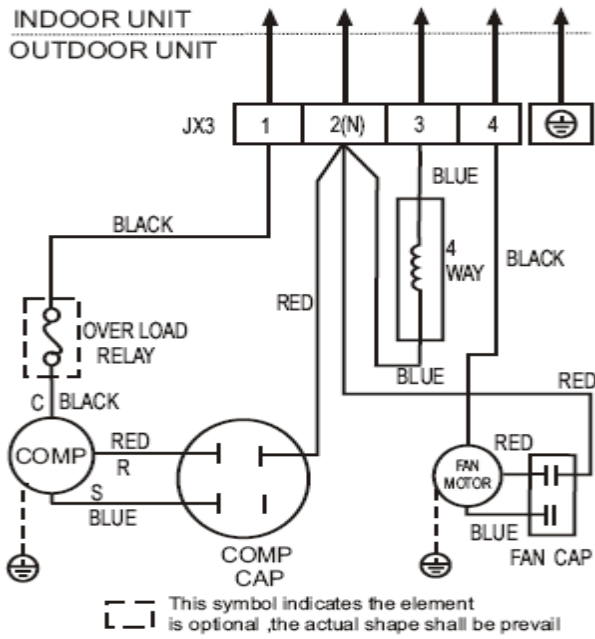

Outdoor :

MSR-09HR-NB6 , MSR-12HR-NB6

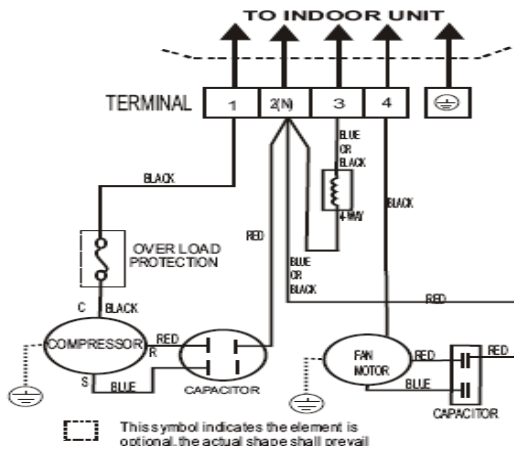

Outdoor :

MSR-12HR-NB4

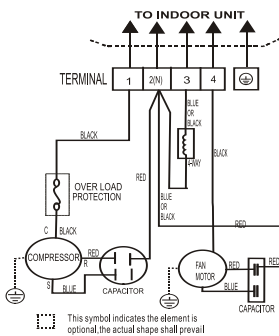

Indoor : -

MSR-18CR-NB4

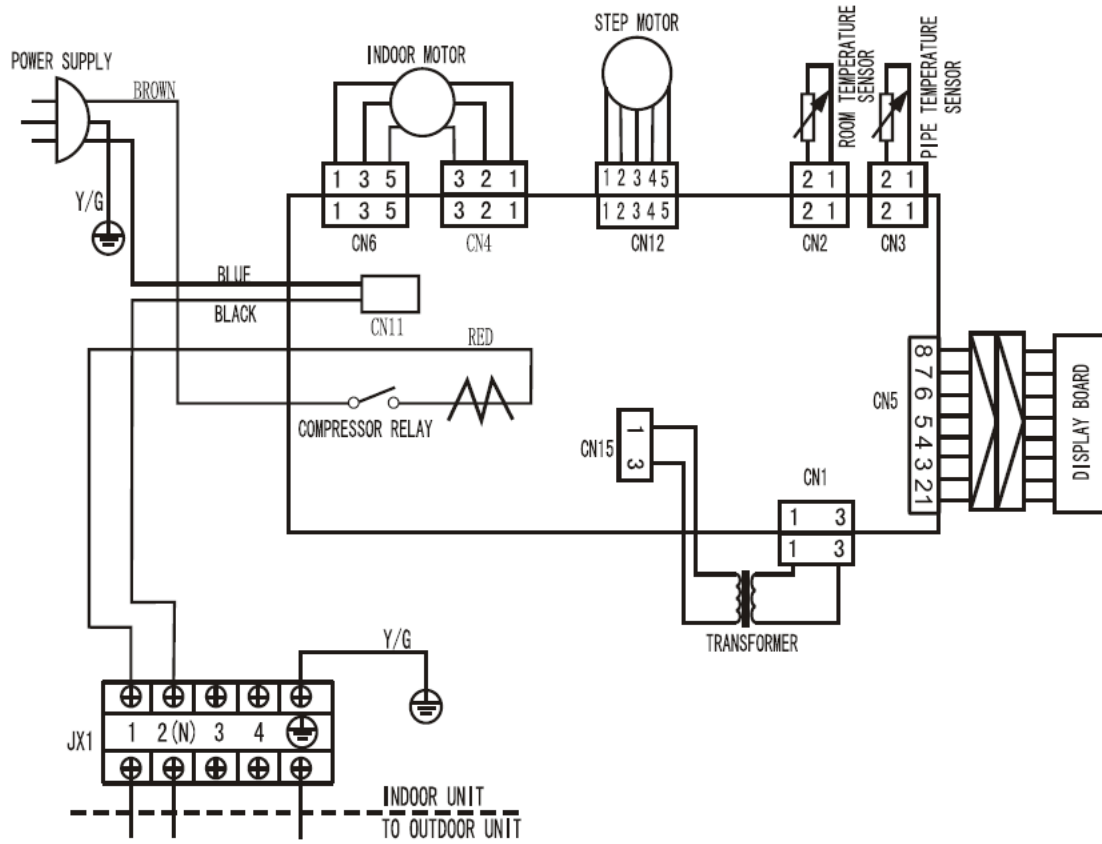

Outdoor :

MSR-18CR-NB4

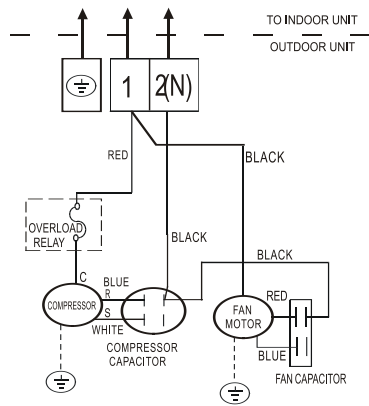

Indoor :

MSR-18HR-NB4

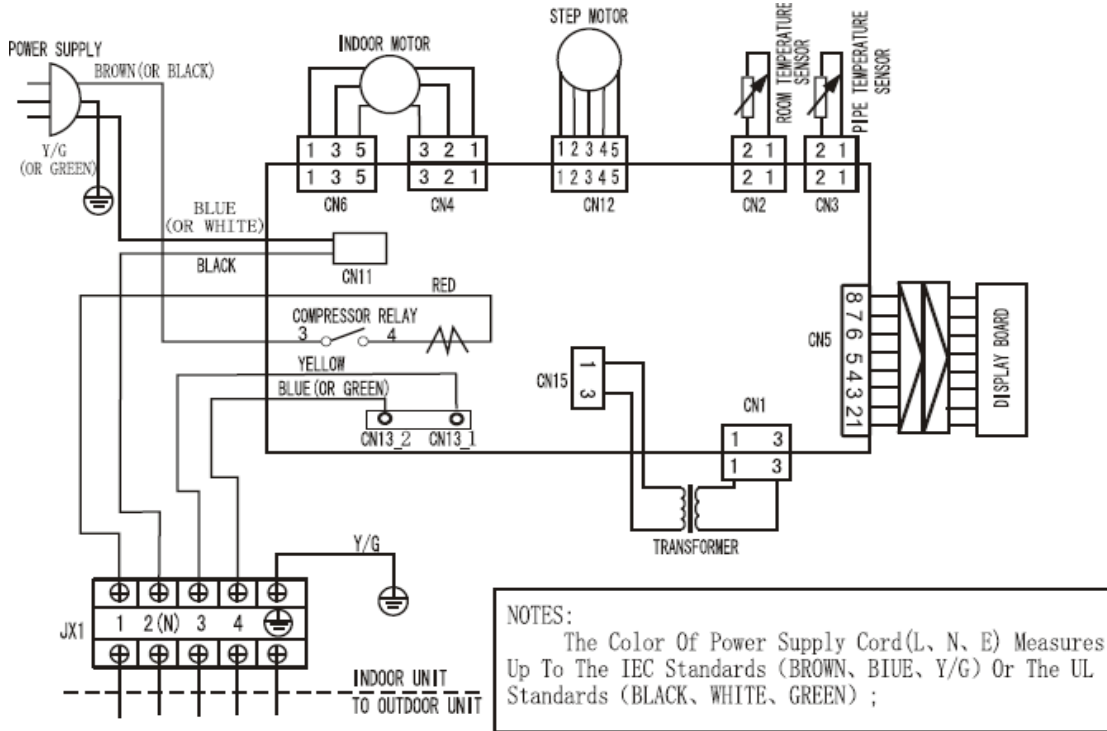

**Outdoor:**

**MSR-18HR-NB4**

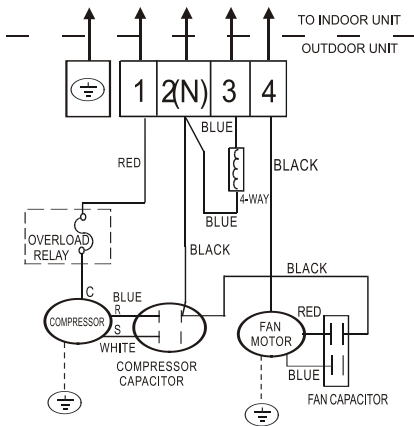

## 7. Installation details

### 7.1 Wrench torque sheet for installation

Outside diameter		Torque
mm	inch	Kg.m
φ6.35	1/4	1.8
φ9.52	3/8	4.2
φ12.7	1/2	5.5

### 7.2 Connecting the cables

The power cord connect should be selected according to the following specifications sheet.

Unit	Grade			
	7K	9K	12K	18K
mm <sup>2</sup>	1.0	1.0	1.5	2.5

### 7.3 Pipe length and the elevation

Capacity Btu/h	Pipe size		Standard length (m)	Max. Elevation B (m)	Max. Pipe length A (m)	Additional refrigerant (g/m)
	GAS	LIQUID				
7K~9K	3/8" (φ9.52)	1/4" (φ6.35)	5	5	10	30
12K	1/2" (φ12.7)	1/4" (φ6.35)	5	5	10	30
18K	1/2" (φ12.7)	1/4" (φ6.35)	5	8	15	30

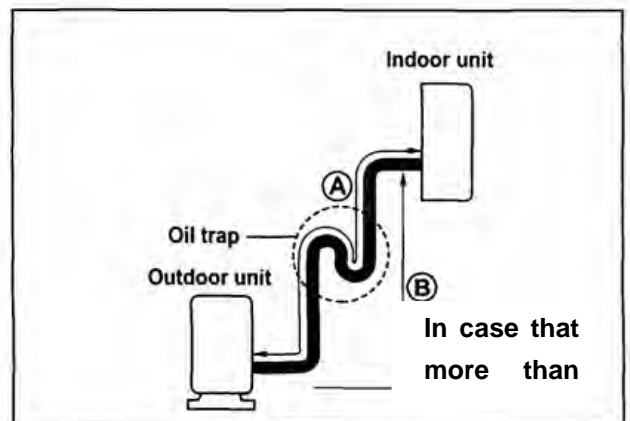
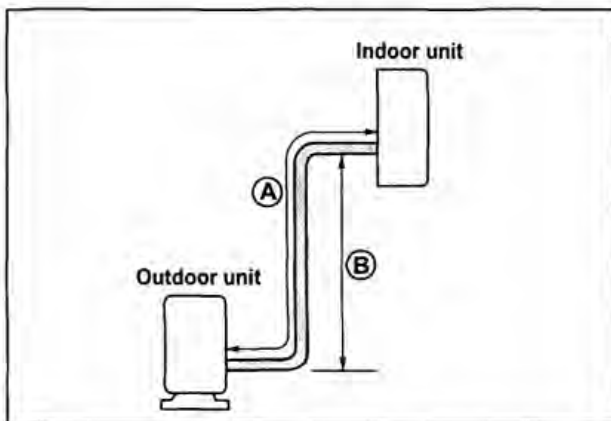

Caution:



Capacity is base on standard length and maximum allowance length is base of reliability.  
Oil trap should be install per 5-7 meters.

## 7.4 Air purging of the piping and indoor unit

### Required tools:

Hexagonal wrench; adjustable wrench; torque wrenches, wrench to hold the joints and gas leak detector.

### Note:

The air in the indoor unit and in the piping must be purged. If air remains in the refrigeration piping, it will affect the compressor, reduce the cooling capacity, and could lead to a malfunction of unit.

Be sure, using a torque wrench to tighten the service port cap (after using the service port), so that it prevents the gas leakage from the refrigeration cycle.

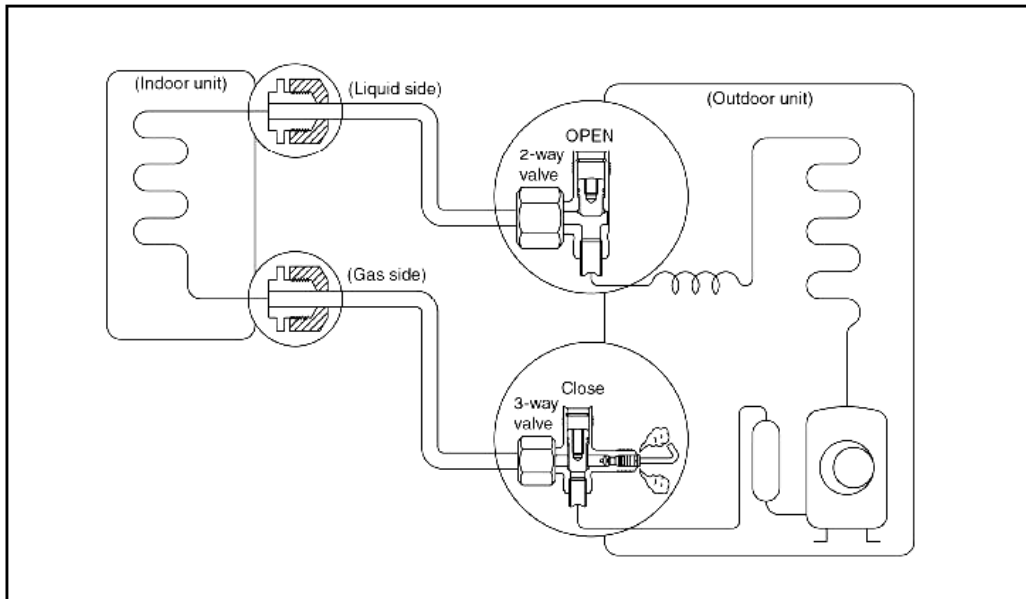

### Procedure

Recheck the piping connections.

Open the valve stem of the 2-way valve counterclockwise approximately 90°, wait 10 seconds, and then set it to closed position.

Be sure to use a hexagonal wrench to operate the valve stem

Check for gas leakage.

Check the flare connection for gas leakage

Purge the air from the system.

Set the 2-way valve to the open position and remove the cap from the 3-way valve's service port.

Using the hexagonal wrench to press the valve core pin, discharge for three seconds and then wait for one minute.

Use torque wrench to tighten the service port cap to a torque of 1.8 kg.m. (18n.m)

Set the 3-way valve to the opened position.

Mounted the valve stem nuts to the 2-way and 3-way valves.

Check for gas leakage.

At this time, especially check for gas leakage from the 2-way and 3-way stem nuts, and from the service port.

### Caution:

If gas leakage is discovered in step (3) above, take the following measures.

If the leaks stop when the piping connections are tightened further, continue working from step (4).

If the gas leaks do not stop when the connections are retightened, repair the location of the leak, discharge all of the gas through the service port, and then recharge with the specified amount of gas from a gas cylinder.

## 7.5 Pumping down (Re-installation)

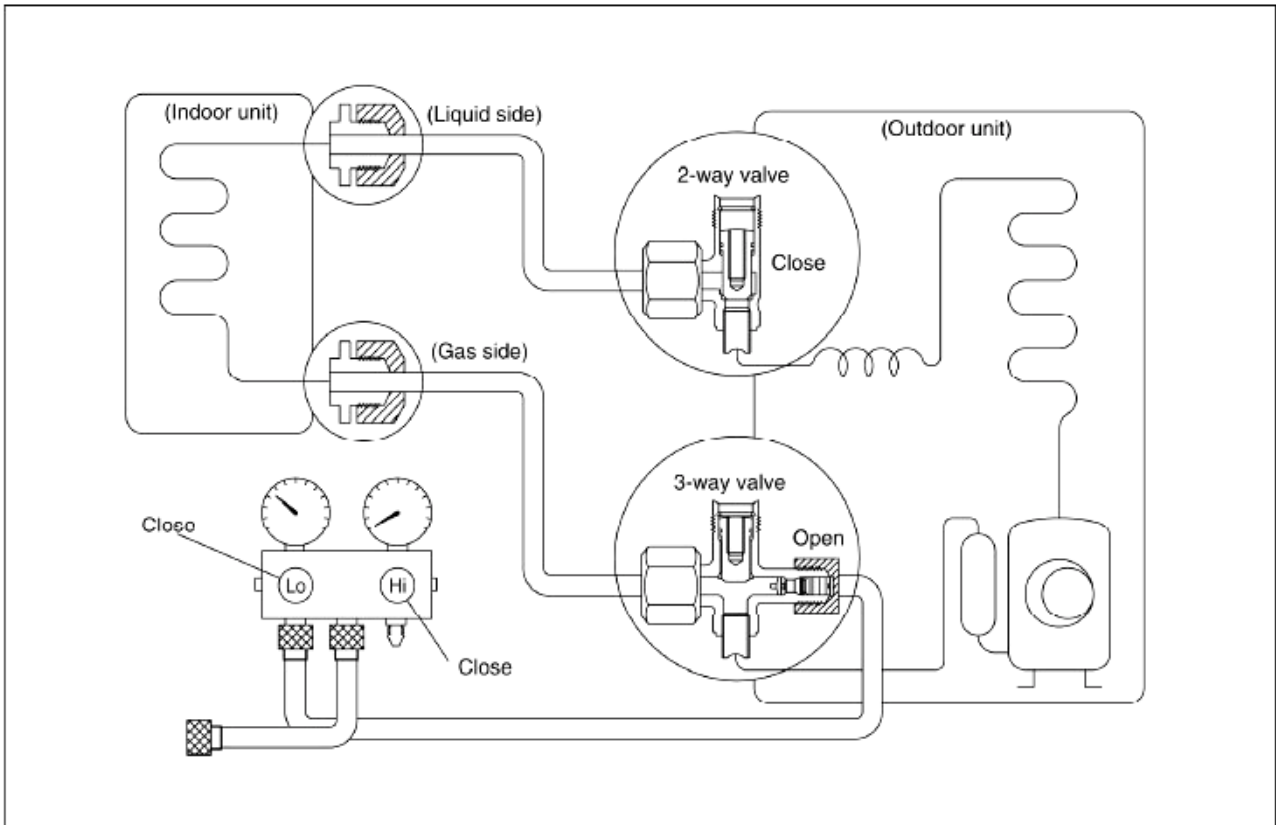

### Procedure

Confirm that both the 2-way and 3-way valves are set to the opened position.

Remove the valve stem caps and confirm that the valve stems are in the opened position.

Be sure to use a hexagonal wrench to operate the valve stems.

Operate the unit for 10 to 15 minutes.

Stop operation and wait for 3 minutes, then connect the charge set to the service port of the 3-way valve.

Connect the charge hose with the push pin to the gas service port.

Air purging of the charge hose.

Open the low-pressure valve on the charge set slightly to purge air from the charge hose.

Set the 2-way valve to the close position.

Operate the air conditioner at the cooling cycle and stop it when the gauge indicates 0.1MPa.

Immediately set the 3-way valve to the closed position.

Do this quickly so that the gauge ends up indicating 0.3 to 0.5Mpa.

Disconnect the charge set, and amount the 2-way and 3-way valve's stem nuts and service port caps.

Use a torque wrench to tighten the service port cap to a torque of 1.8 kg.m.

Be sure to check for gas leakage.

## 7.6 Re-air purging (Re-installation)

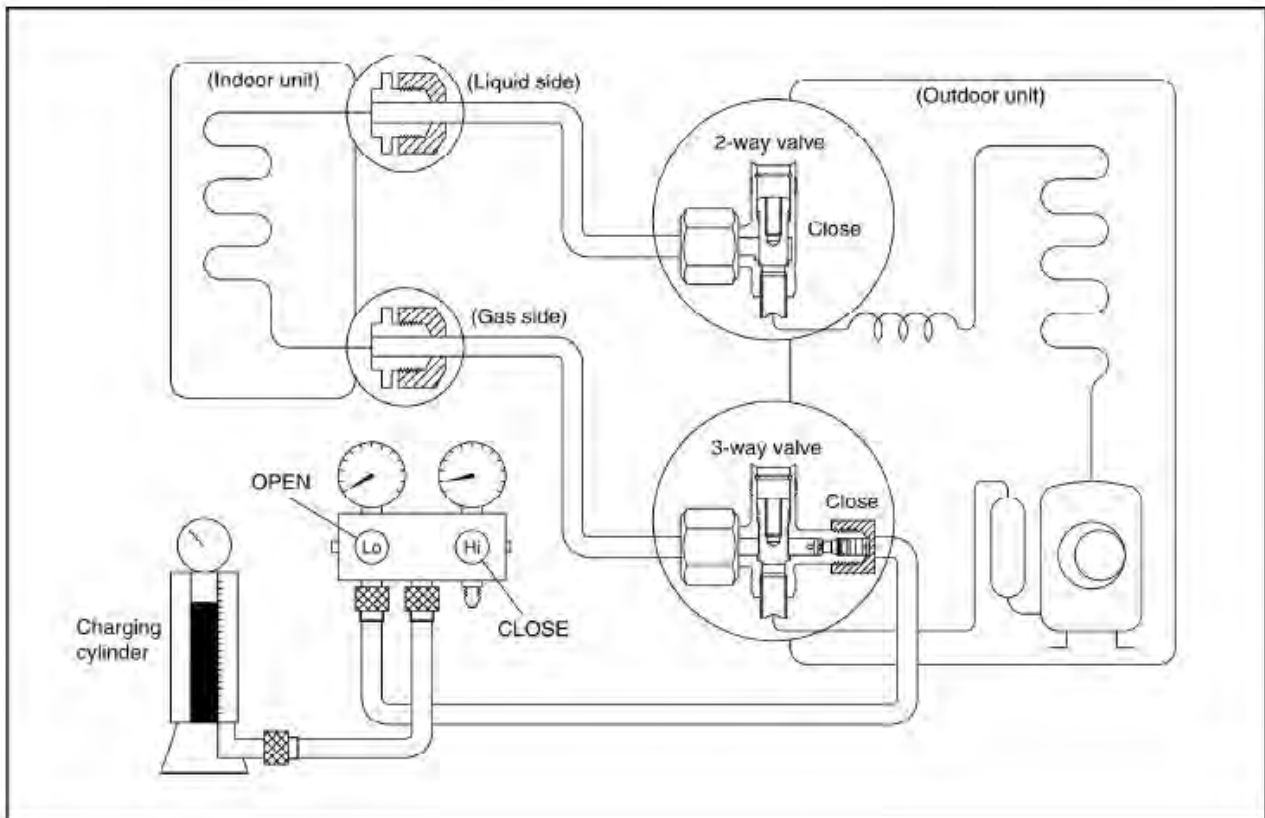
**Procedure:**

Confirm that both the 2-way and 3-way valves are set to the closed position.

Connect the charge set and a charging cylinder to the service port of the 3-way valve.

Leave the valve on the charging cylinder closed.

**Air purging.**

Open the valves on the charging cylinder and the charge set. Purge the air by loosening the flare nut on the 2-way valve approximately 45° for 3 seconds then closing it for 1 minutes; repeat 3 times.

After purging the air, use a torque wrench to tighten the flare nut to on the 2-way valve.

Check the gas leakage.

Check the flare connections for gas leakage.

Discharge the refrigerant.

Close the valve on the charging cylinder and discharge the refrigerant until the gauge indicate 0.3 to 0.5 Mpa.

Disconnect the charge set and the charging cylinder, and set the 2-way and 3-way valves to the open position.

Be sure to use a hexagonal wrench to operate the valve stems.

Mount the valve stems nuts and the service port cap.

Be sure to use a torque wrench to tighten the service port cap to a torque 18N.m.

Be sure to check the gas leakage.

7.7 Balance refrigerant of the 2-way, 3-way valves

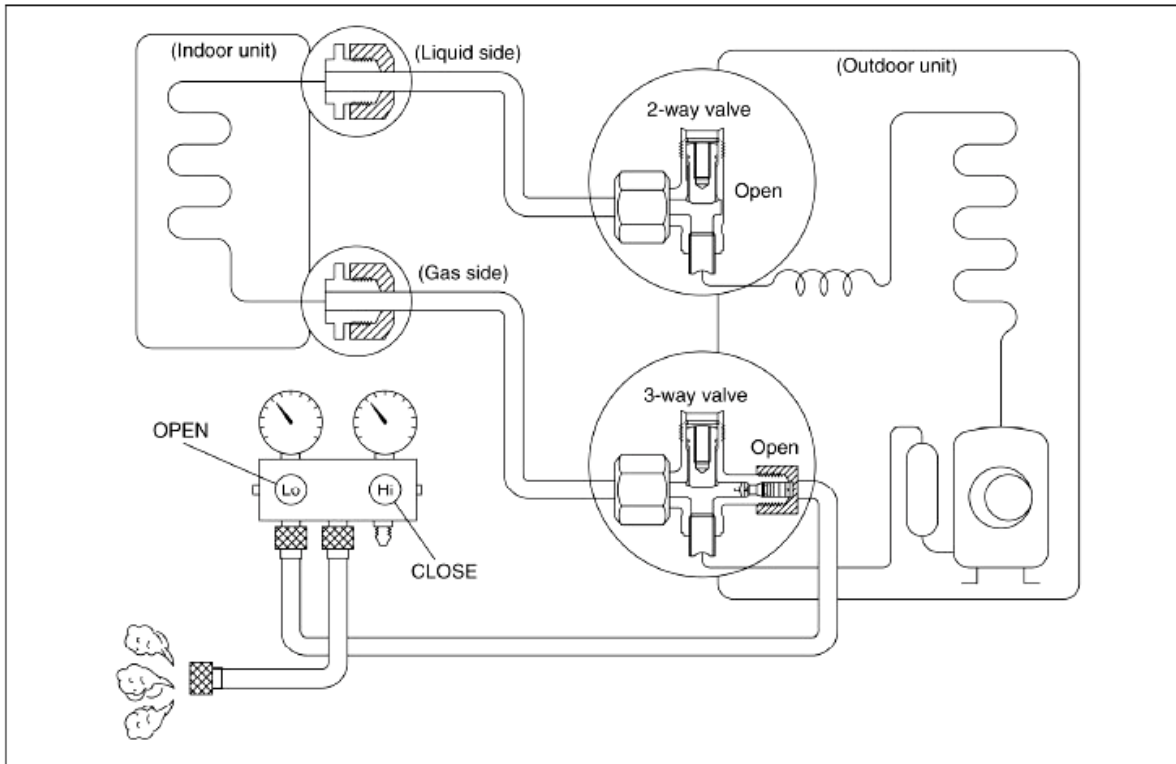

**Procedure:**

**Confirm that both the 2-way and 3-way valves are set to the open position.**

**Connect the charge set to the 3-way valve's service port.**

**Leave the valve on the charge set closed.**

**Connect the charge hose with the push pin to the service port.**

**Open the valves (Low side) on the charge set and discharge the refrigerant until the gauge indicates 0.05 to 0.1 Mpa.**

**If there is no air in the refrigeration cycle [the pressure when the air conditioner is not running is higher than 0.1Mpa, discharge the refrigerant until the gauge indicates 0.05 to 0.1 Mpa. If this is the case, it will not be necessary to apply a evacuation.**

**Discharge the refrigeration gradually; if it is discharged too suddenly, the refrigeration oil will be discharged.**

7.8 Evacuation

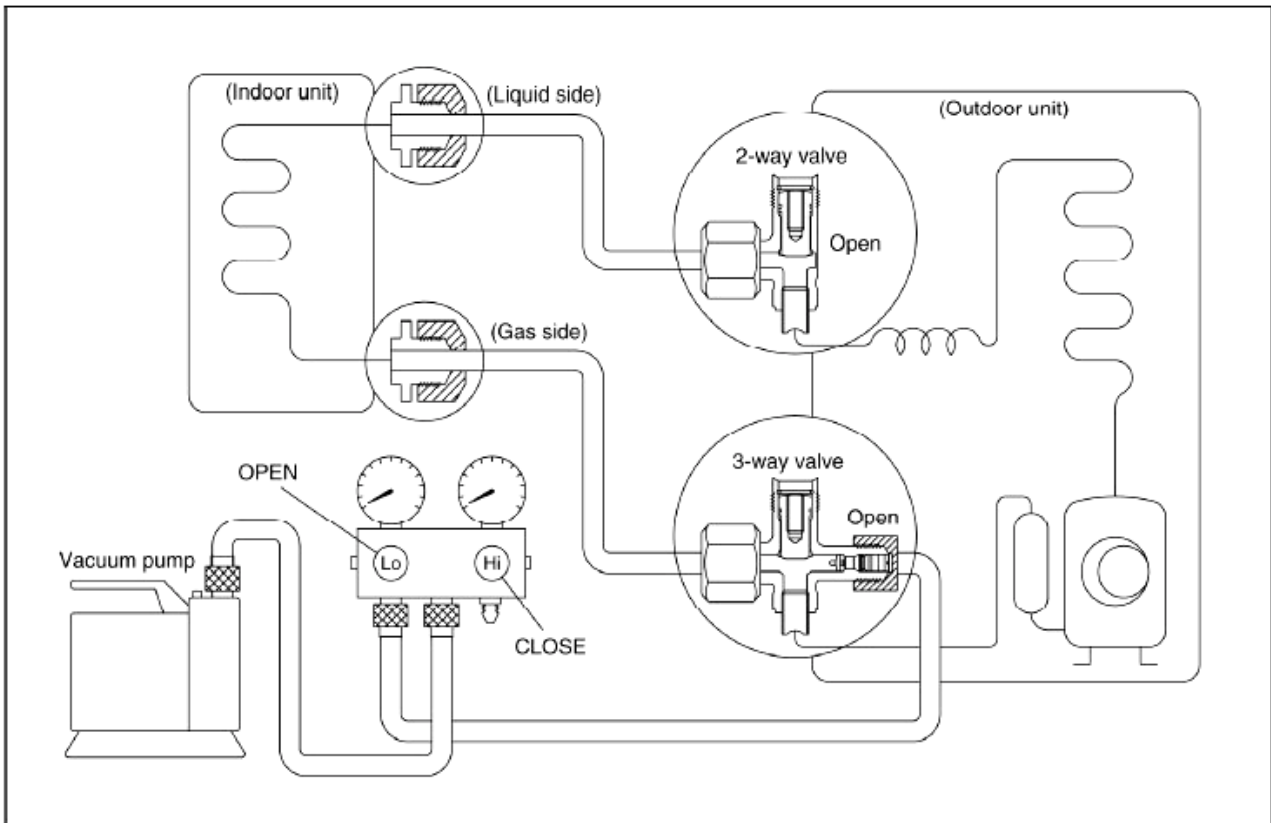

**Procedure:**

**Connect the vacuum pump to the charge set's centre hose.**

**Evacuation for approximately one hour.**

**Confirm that the gauge needle has moved toward -0.1 Mpa (-76 cmHg) [vacuum of 4 mmHg or less].**

**Close the valve (Low side) on the charge set, turn off the vacuum pump, and confirm that the gauge needle does not move (approximately 5 minutes after turning off the vacuum pump).**

**Disconnect the charge hose from the vacuum pump.**

**Vacuum pump oil, if the vacuum pump oil becomes dirty or depleted, replenish as needed.**

## 7.9 Gas charging

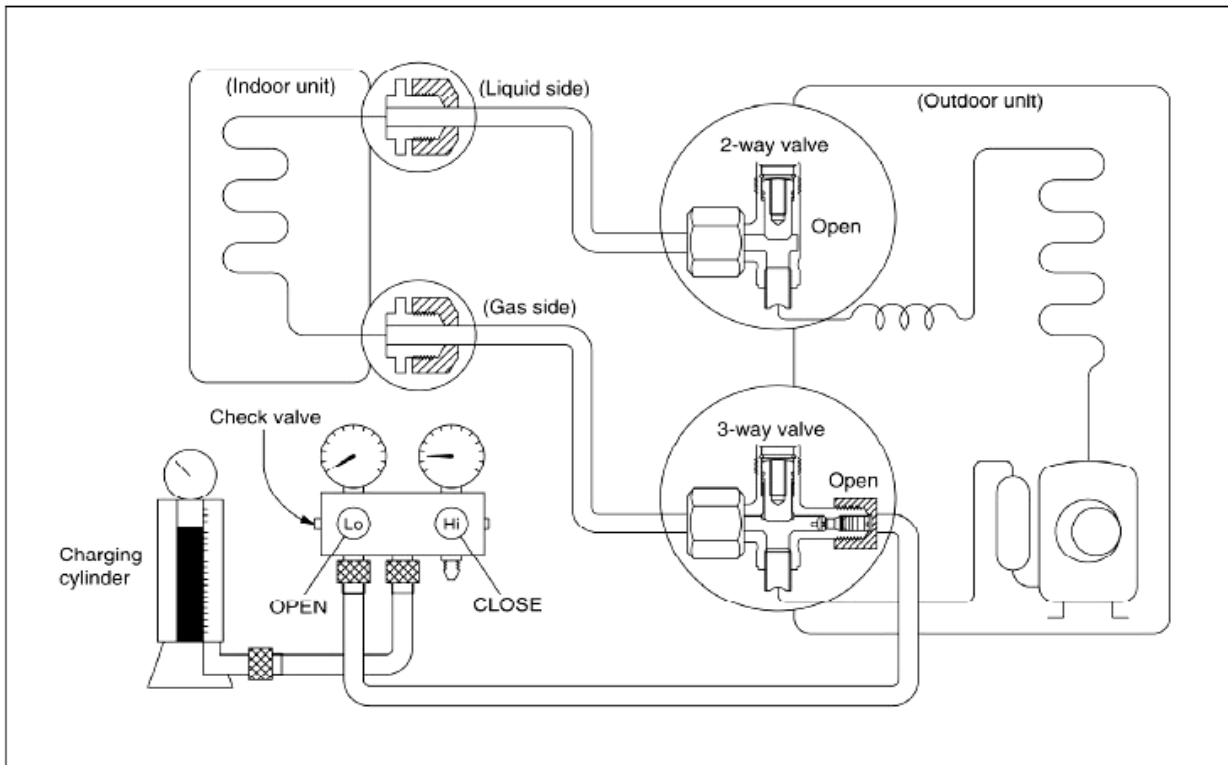
**Procedure:**

1. Connect the charge hose to the charging cylinder.
  - **Connect the charge hose which you disconnected from the vacuum pump to the valve at the bottom of the cylinder.**
2. Purge the air from the charge hose.
  - **Open the valve at the bottom of the cylinder and press the check valve on the charge set to purge the air (be careful of the liquid refrigerant).**
3. Open the valves (Low side) on the charge set and charge the system with liquid refrigerant.
  - **If the system cannot be charge with the specified amount of refrigerant, it can be charged with a little at a time (approximately 150g each time) while operating the air conditioner in the cooling cycle; however, one time is not sufficient, wait approximately 1 minute and then repeat the procedure.(pumping down-pin).**
4. Immediately disconnect the charge hose from the 3-way valve's service port.
  - **Stopping partway will allow the refrigerant to be discharged.**
  - **If the system has been charged with liquid refrigerant while operating the air conditioner, turn off the air conditioner before disconnecting the hose.**
5. Mounted the valve stem caps and the service port
  - **Use torque wrench to tighten the service port cap to a torque of 18N.m.**
  - **Be sure to check for gas leakage.**

## 8. Electronic function

### 8.1 Proper symbols and their meaning

**TA:** Indoor ambient temperature

**TE:** Indoor evaporator temperature

**TS:** Setting temperature through the remote controller

**I<sub>3sec</sub>:** Self-protection amp of compressor, continue three seconds until turns off the compressor.

**I<sub>5MIN</sub>:** Self-protection amp of compressor, continue five minutes until turns off the compressor.

**I<sub>FAN</sub>:** Self-protection amp of outdoor fan/indoor fans when they change from higher wind to lower wind.

**I<sub>RESTORE</sub>:** Amp self-protection return value

**TH<sub>DEFROST</sub>:** High wind, defrosting temperature difference

**TM<sub>DEFROST</sub>:** Middle wind, defrosting temperature difference

**TL<sub>DEFROST</sub>:** Low wind, defrosting temperature difference

**TE1:** Anti-cold wind, from Fan Off to Breeze temperature

**TE2:** Anti-cold wind, from Breeze to Setting Fan Speed temperature

**TE3:** Anti-cold wind, from Setting Fan Speed to Breeze temperature

**TE4:** Anti-cold wind, from Breeze to Fan Off temperature

**TE5:** Evaporator low temperature protection entering temperature

**TE6:** Evaporator low temperature protection restoring temperature

**TE7:** Evaporator high temperature protection, compressor off temperature

**TE8:** Evaporator high temperature protection, fan off temperature

**TE9:** Evaporator high temperature protection, restoring temperature

### 8.2 Function

Remote receiving

Testing and forced running

Position set for indoor unit wind vane

LED displaying and alarm

On or off Timer

Protection for the compressor

Current protection

High temperature protection of indoor heat exchanger at heating mode

Auto defrosting and heating recovery at heating mode

Anti cold air at heating mode

Anti frozen at cooling mode

### 8.3 Protection

8.3.1 3 minutes delay at restart for compressor.

8.3.2 Sensor protection at open circuit and breaking disconnection

8.3.3 Fan Speed is out of control. When Indoor Fan Speed is too high(higher than 2100RPM)or too low(lower than 300RPM) lasting 50 seconds, the unit stops and LED displays failure information and can't returns to normal operation automatically.

8.3.4 Cross Zero signal error warning. If there is no Cross Zero signals in 4 minutes, the unit stops and LED displays failure information and can't returns to normal operation automatically.

8.3.5 The current protection of the compressor



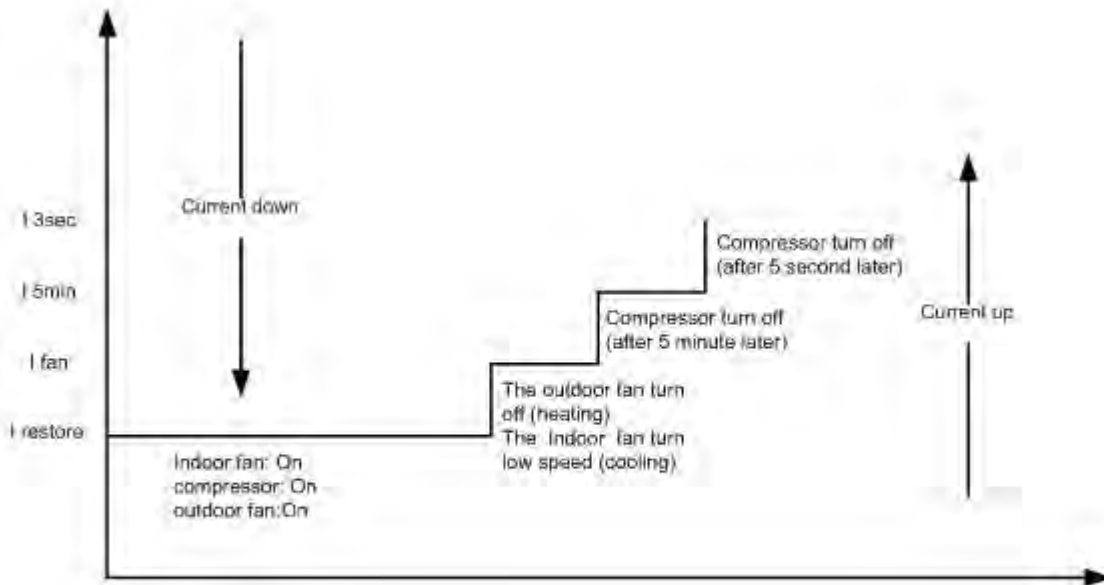

If compressor turns off for continuously 4 times due to current protection in 5 minutes from Compressor On, the unit stops and LED displays failure information and can't returns to normal operation automatically.

**8.4 Fan-only mode**

Fan speed is high/mid/low/ Auto

**8.5 Cooling mode**

The 4-way valve is closed at cooling mode.

The action of the compressor and the outdoor fan:(T=indoor temperature)

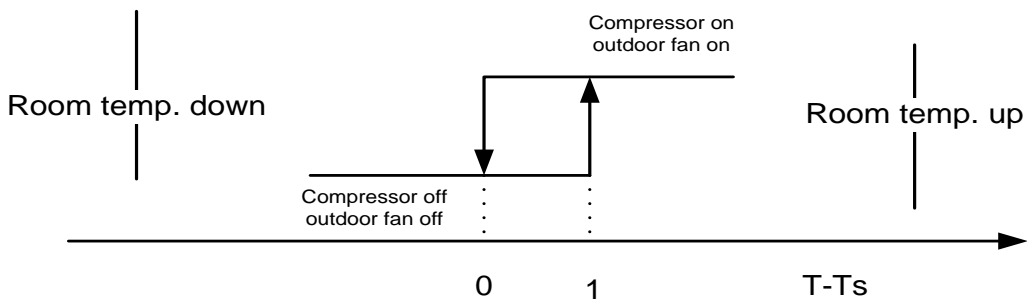

Auto fan at cooling mode:

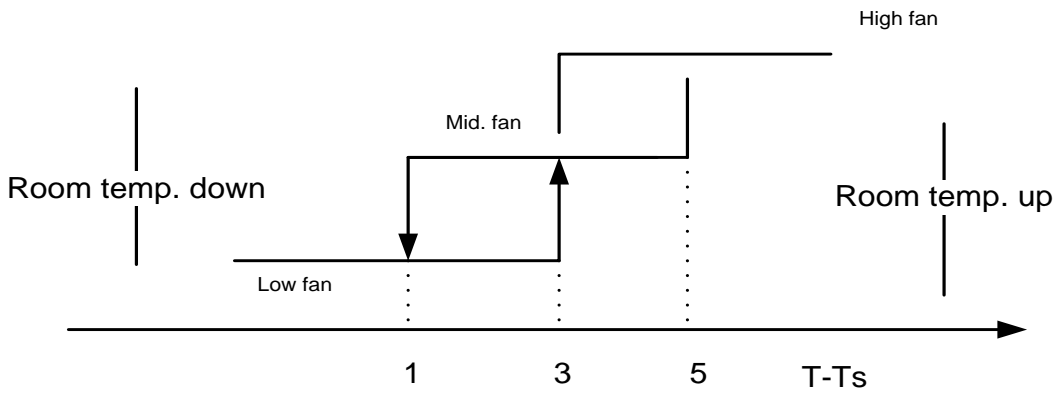

**Anti-freezing control to indoor evaporator at cooling mode ( T: evaporator temp. )**

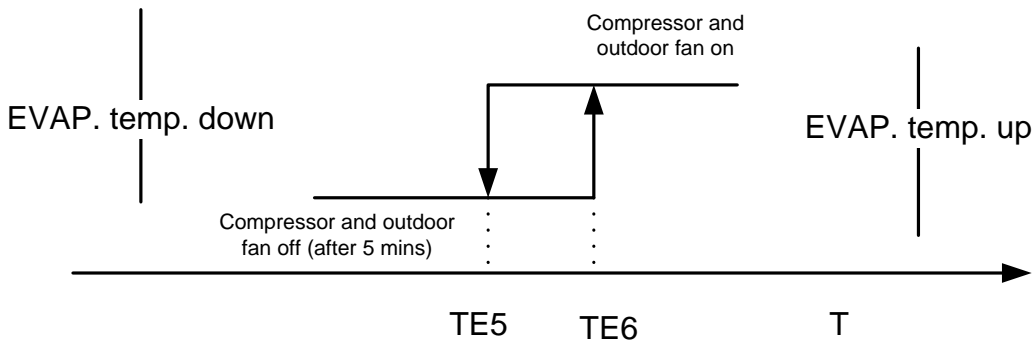

**8.6 Dehumidifying mode**

**8.6.1 The 4-way valve is off in dehumidifying mode**

**8.6.2 Compressor and Indoor Fan actions in dehumidifying mode**

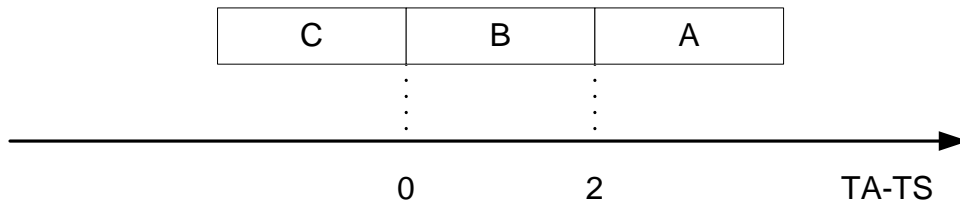

Block	Indoor Fan	Compressor and Outdoor Fan
A	LOW	ON 6minutes
	BREEZE	OFF 4minutes
B	LOW	ON 5minutes
	BREEZE	OFF 5minutes
C	LOW	ON 4minutes
	BREEZE	OFF 6minutes

Repeat on and off cycle.

**8.6.3 Low room temperature protection:**

When room temperature decreases to below 10°C, compressor and outdoor fan will stop(indoor fan is Breeze). Dehumidifying operation will be resumed when room temperature restores to over 13°C.

**8.6.4 At dehumidifying mode, the anti-freezing function of the indoor heat exchanger is the same as**

that of cooling mode.

8.6.5 At dehumidifying mode, the action of fans of indoor is the same as that of air-only mode.

8.7 Heating mode

8.7.1 Generally, the 4-way valve is open in heating mode, but it is closed in defrosting mode. 4-way valve must delay 2 minutes compared with compressor if the compressor changed into non-heating mode or turned off. 4-way valve doesn't delay in dehumidifying mode

8.7.2 Generally, the outdoor fan is turned off with the on-off action of compressor in heating mode, except for the defrosting mode or the end of defrost

8.7.3 Action of compressor and outdoor fan motor at heating mode: compressor must run for 7 minutes after starting and then judge temperature. Meanwhile other protections are still valid.

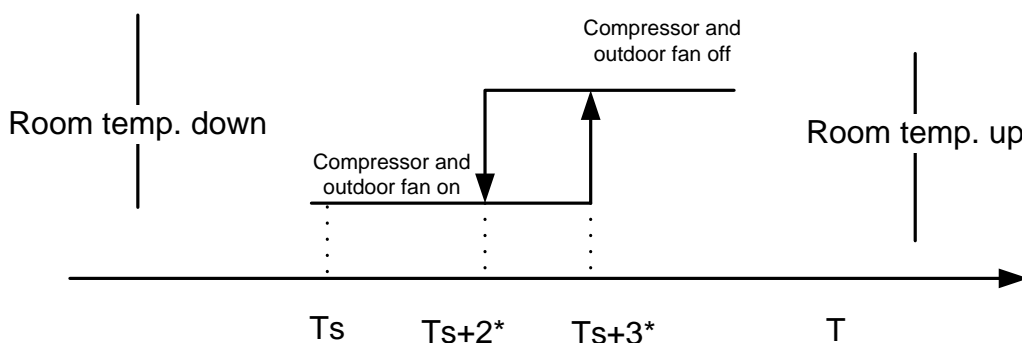

\* This parameter can be changed from 0 to 3

8.7.4 Indoor Fan actions at heating mode

Indoor Fan can be set at HIGH/MID/LOW/AUTO by using a remote controller, but Anti-cold wind function prevails.

Anti-cold wind control function at heating mode (T=indoor exchanger temp.)

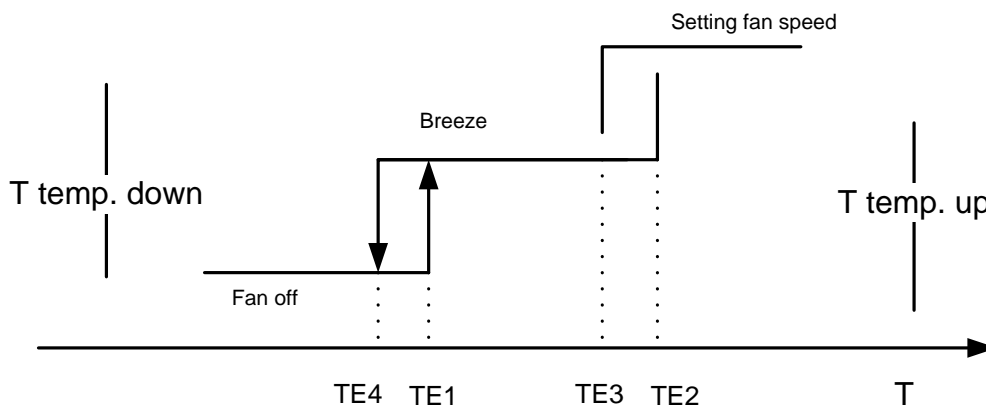

8.7.5 Auto wind at heating mode (T=indoor temp.)

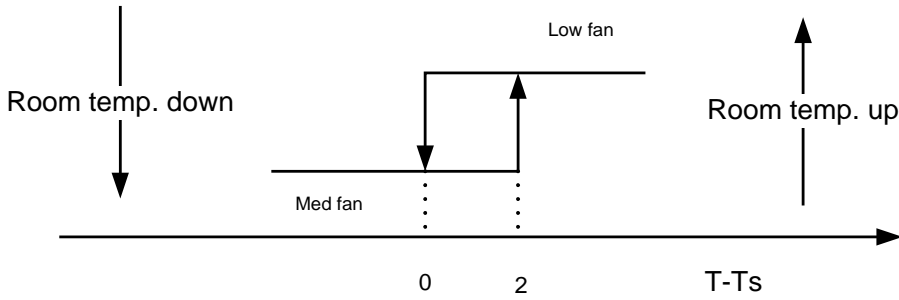

**8.7.6 Indoor evaporator high-temperature protection at heating mode**  
(T=indoor exchanger temp.)

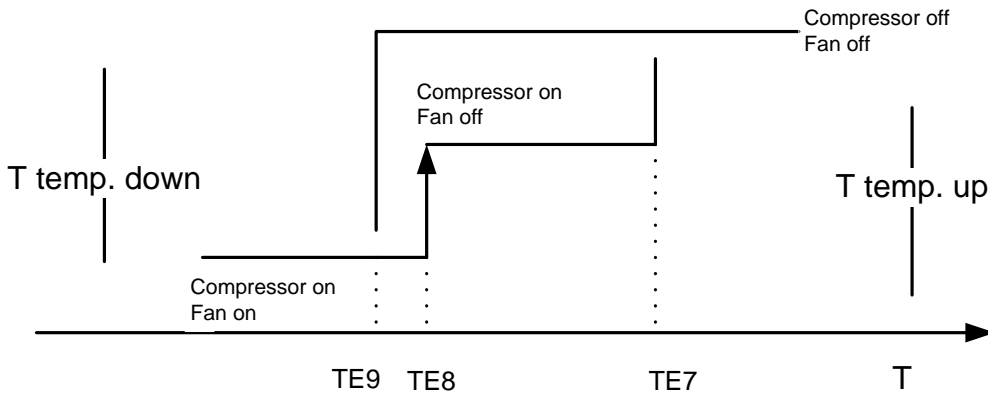

**8.7.7 The louver opens to Standard Angle ANGLHEAT when power is on for the first time**

**8.8 Defrosting mode (available for heating mode)**

**8.8.1 Defrosting condition: Defrosting starts when either of the following ①&②:**

① A and B are satisfied:

**A: The compressor keeps running for 40 minutes or more.**

**B: The temperature difference of evaporator and room temperature meets one of the following:**

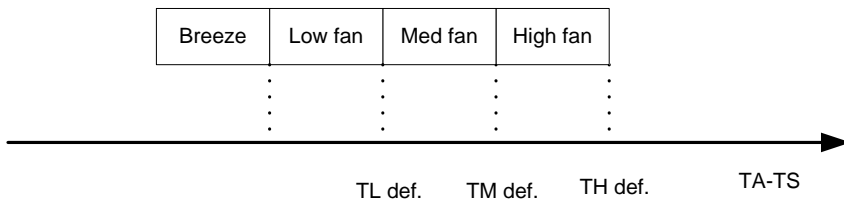

**8.8.2 ② Calculate from the end of latest defrost, evaporator high temp. Protection only closes outdoor fan with the compressor still running. Add up to 90 minutes.**

**8.8.3 Defrosting time**

At condition ①, If item B is satisfied before item A, it would be regarded as severe frosting and the defrosting time is 10 minutes. If item B is satisfied after item A, the defrosting time is 7.5minutes.

At condition ②, the defrosting time is 10 minutes.

After three times continuous 7.5-minute defrost, the fourth defrost time should be 10 minutes.

The circulation is as following:

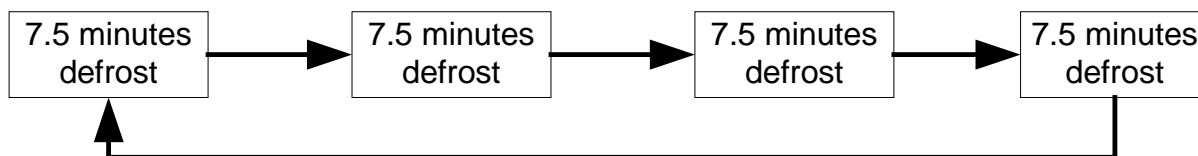

### 8.8.4 Ending condition of defrosting

If one of following conditions is satisfied, end the defrost and turn into heating mode:

- A. The defrost time has reached to 7.5 or 10 minutes.
- B. The compressor current has reached to  $I_{DEFROST}$  or above,  $I_{DEFROST}$  differs in different models

### 8.8.5 Defrosting Actions

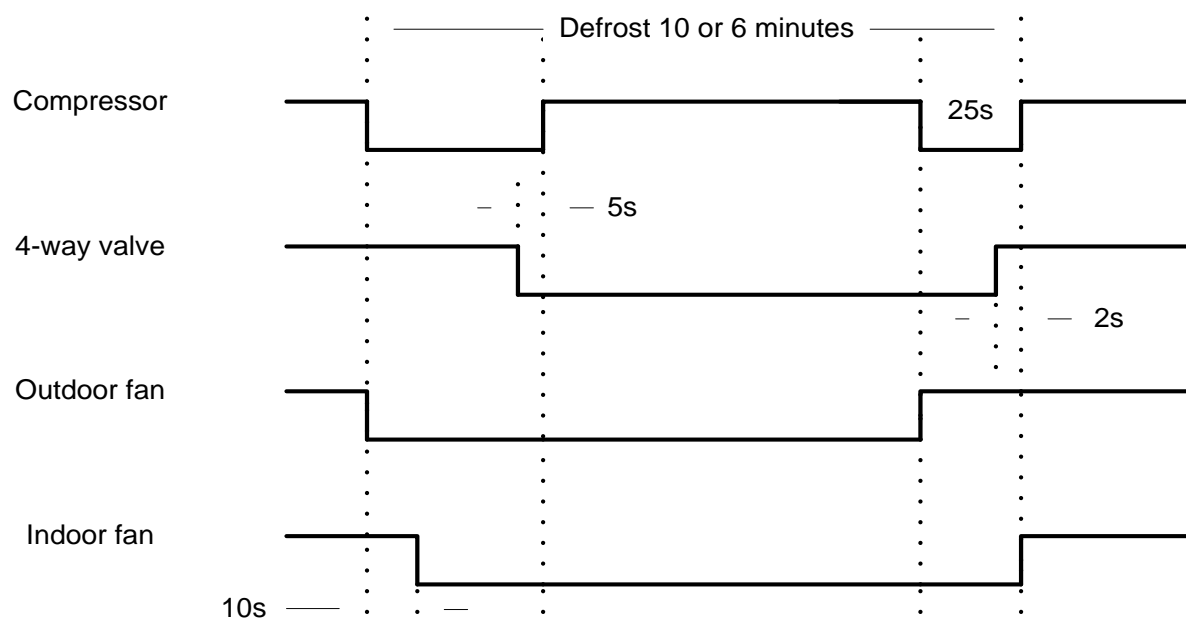

## 8.9 Auto mode

8.9.1 The air conditioner automatically selects one of the following operation modes: cooling, heating or fan only according to the temperature difference between room temperature (TA) and set temperature (TS).

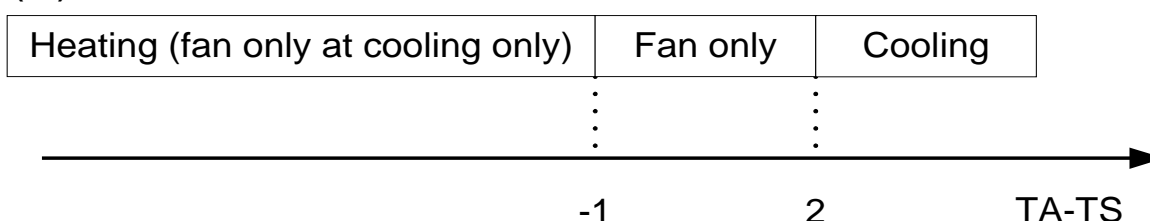

8.9.2 The indoor fan blows automatically in corresponding selected mode

8.9.3 The motion of indoor fan's blade should accord with the selected operation mode

8.9.4 One mode should be carried out for at least 15 minutes once selected. If the compressor cannot start for 15 minutes, reselect the operation mode according to the room temp. and set temp., or reselect

when the set temp. varies

### 8.10 Force cooling function

8.10.1 Select forced cooling function with the forced cooling button or the switch

8.10.2 The compressor is unconditionally turned on, after 30 minutes cooling operation whose fan mode is set as low, the A/C operates at the DRY mode with a set temp. of 24°C

8.10.3 All protections of remote control cooling are available at forced cooling operation

8.10.4 Forced Auto function

Select forced auto function with the forced auto button or the switch.

In forced auto status the A/C operates at remote control mode with a set temp. of 24°C

### 8.11 Sleep mode

8.11.1 The sleep function is available at cooling, heating or auto mode

8.11.2 Cooling:

The set temperature rise 1°C per hour. Two hours later, the set temperature will maintain as a constant and the fan speed is kept at low speed.

The total time is 7 hours, after 7 hours the unit stops

8.11.3 Heating:

The set temperature decrease 1°C per hour. Two hours later, the set temperature will maintain as a constant and the air circulation is kept at low speed (Anti-cold function takes precedence over all).

The total time is 7 hours, after 7 hours the unit stops

8.11.4 Auto:

After an hour running under economic mode, the set temp will rise 1°C, if it is under cooling mode; the set temp will decrease 1°C, if it is under heating mode; the set temp will be changeless, if it is under fan-only mode; the condition will be the same after the air conditioner running under economic mode after 2 hours, and during the next time the set temp do not change. The total time is 7 hours, after 7 hours the unit stops.

### 8.12 Auto restart function

In case of a sudden power failure, this function automatically sets the unit to previous settings before the power failure when power returns

### 8.13 Turbo mode

In cooling mode, when pressing the turbo button on the remote controller, the unit will enter turbo mode with ultra-high speed and reach the set temperature more quickly. After running 20 minutes in turbo mode, the indoor fan will automatically recover the preset speed.

## 9. Model and Parameters

Model	MSR-07C(H)R(B6)	MSR-09C(H)RRB4	MSR-12C(H)R4(B6)	MSR-18C(H)RRB6)
I3SEC	8.5A	10A	12A	16A
I5MIN	6.5A	8.5A	10A	15A
IFAN	5.5A	6.5A	9A	11A
IRESTORE	4.5A	5.5A	8A	9.5A
IDEFROST	3.5A	4.5A	6.5A	7.5A
TE1	28°C	28°C	34°C	34°C
TE2	32°C	32°C	37°C	36°C
TE3	30°C	30°C	33°C	30°C
TE4	26°C	26°C	22°C	20°C
TE5	4°C	4°C	4°C	3°C
TE6	10°C	10°C	10°C	14°C
TE7	60°C	60°C	63°C	60°C
TE8	53°C	53°C	53°C	52°C
TE9	50°C	51°C	52°C	51°C
ANGLCOOL	88	88	88	88
ANGLHEAT	125	125	125	125
ANGLOFF	0	0°	0	0
THDEFROST	15°C	17°C	18°C	17°C
TMDEFROST	16°C	18°C	19°C	18°C
TLDEFROST	17°C	19°C	20°C	19°C

## 10. Troubleshooting

### 10.1 Display board

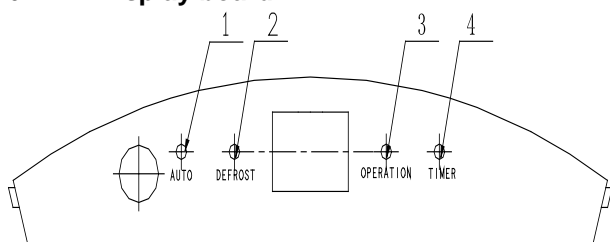

- **Operation**

The indicator flashes once every second after power is on and illuminates when the air conditioner is in operation.

- **Timer indicator:**

The indicator illuminates then **TIMER** is set **ON**.

- **PRE-DEF. indicator (For cooling & heating mode only)**

The air conditioner starts defrosting automatically if outdoor unit frosts in heating operating.

At this time, **PRE-DEF.** indicator illuminates.

- **Auto indicator:**

This indicator flashes when the air conditioner is in **AUTO** operation.

- **ECON indicator**

This indicator illuminates while the air conditioner is in economic operation.

### 10.2 Troubleshooting

Failure phenomenon	Operation lamp	Timer lamp
Indoor fan speed has been out of control for over 1 minute	☆	X
Indoor room temp. or evaporator sensor is open circuit or short circuit	☆	On
Over current protection of the compressor occurs 4 times	X	☆
EEROM error	On	☆
No over-zero signal	☆	☆

✕ Extinguish

☆ Flash at 5Hz



10.3 Diagnostic chart

After energizing, no indicator is lighted and the air conditioner can't be operated.

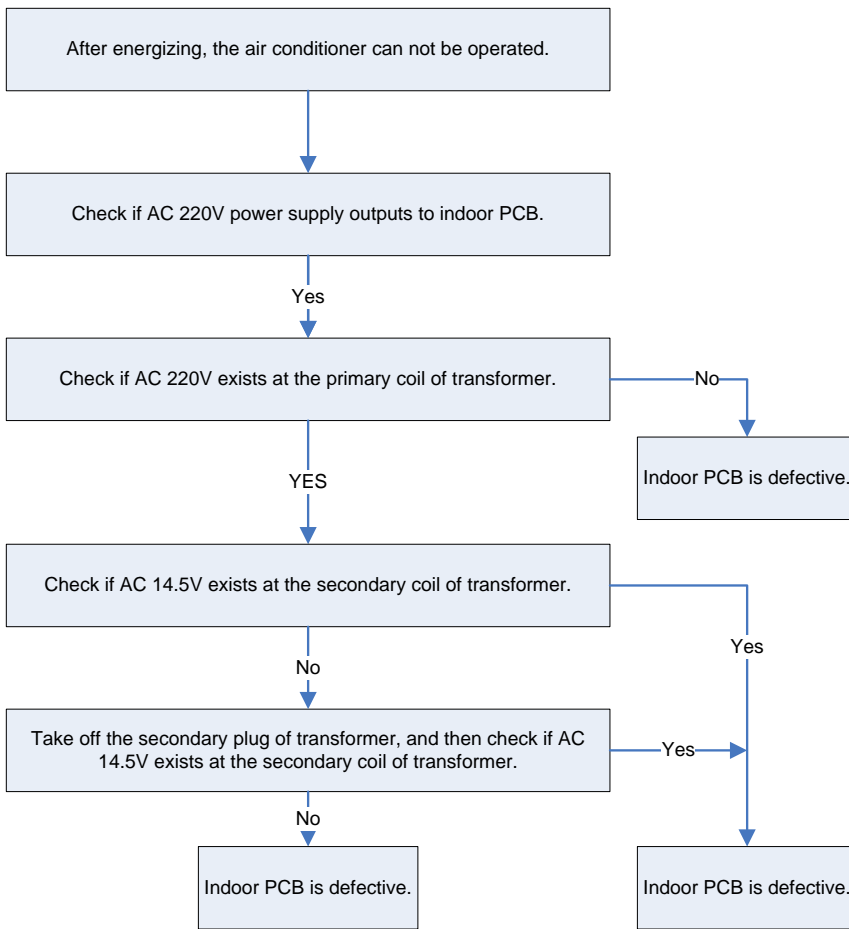

10.4 Resetting phenomenon often occurs during operation.

(That is automatically entering to the status when power is on.)

The reason is that the instantaneous voltage of main chip is less than 4.5V. Check according to the following procedure:

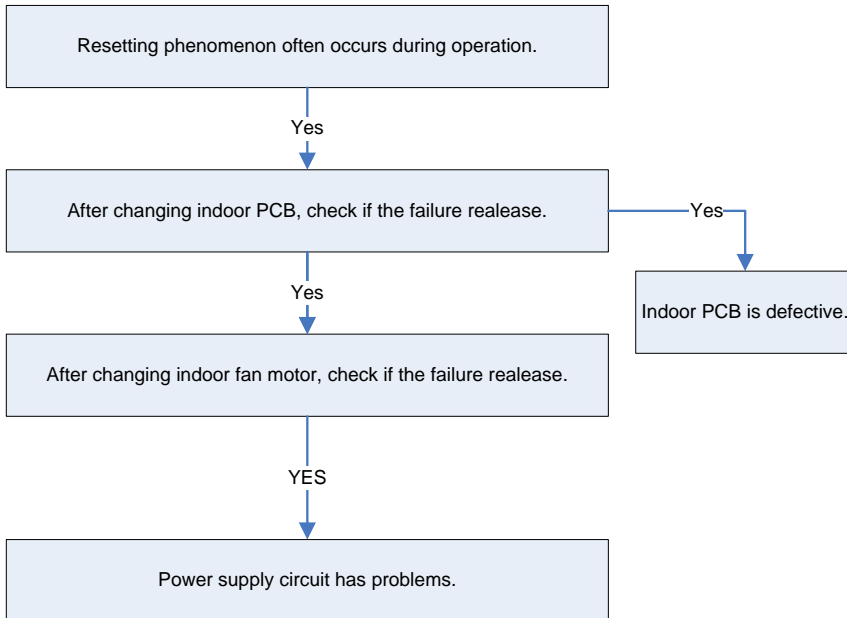

10.5 Operation lamp flashes and Timer lamp off.

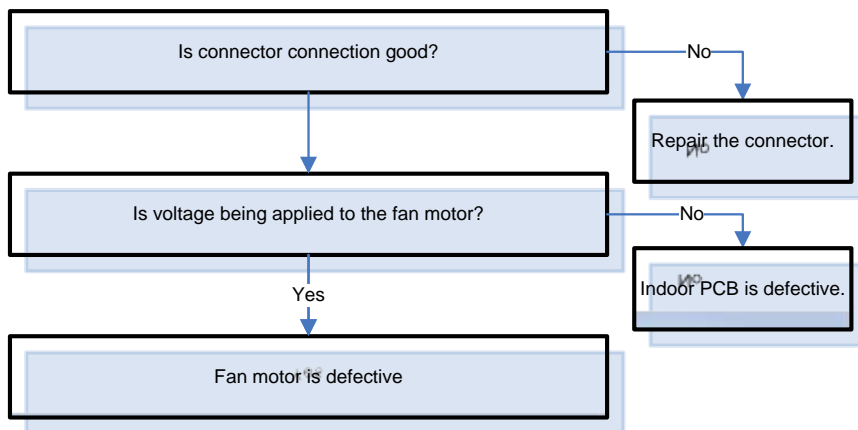

10.6 Operation lamp flashes and Timer lamp on.

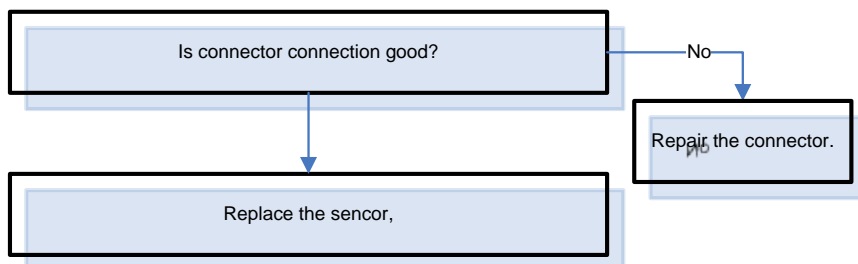

10.7 Operation lamp off and Timer lamp flashes

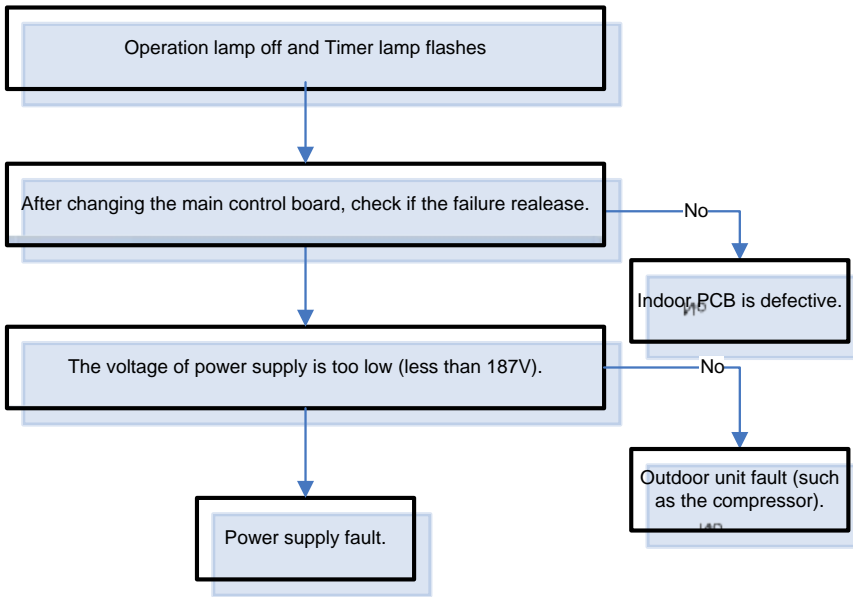

10.8 Operation lamp on and Timer lamp flashes

**EEROM error, indoor PCB is defective.**

10.9 Operation lamp flashes, Timer lamp flashes .

**This is alarm signal when the main chip can't detect over-zero signal. When such failure occurs, the main control board must have fault.**

## 11. Characteristic of temperature sensor

Temp.°C	Resistance KΩ	Temp.°C	Resistance KΩ	Temp.°C	Resistance KΩ
-10	62.2756	17	14.6181	44	4.3874
-9	58.7079	18	13.918	45	4.2126
-8	56.3694	19	13.2631	46	4.0459
-7	52.2438	20	12.6431	47	3.8867
-6	49.3161	21	12.0561	48	3.7348
-5	46.5725	22	11.5	49	3.5896
-4	44	23	10.9731	50	3.451
-3	41.5878	24	10.4736	51	3.3185
-2	39.8239	25	10	52	3.1918
-1	37.1988	26	9.5507	53	3.0707
0	35.2024	27	9.1245	54	2.959
1	33.3269	28	8.7198	55	2.8442
2	31.5635	29	8.3357	56	2.7382
3	29.9058	30	7.9708	57	2.6368
4	28.3459	31	7.6241	58	2.5397
5	26.8778	32	7.2946	59	2.4468
6	25.4954	33	6.9814	60	2.3577
7	24.1932	34	6.6835	61	2.2725
8	22.5662	35	6.4002	62	2.1907
9	21.8094	36	6.1306	63	2.1124
10	20.7184	37	5.8736	64	2.0373
11	19.6891	38	5.6296	65	1.9653
12	18.7177	39	5.3969	66	1.8963
13	17.8005	40	5.1752	67	1.830
14	16.9341	41	4.9639	68	1.7665
15	16.1156	42	4.7625	69	1.7055
16	15.3418	43	4.5705	70	1.6469