



SPLIT TYPE ROOM AIR CONDITIONER

**Split Wall Mounted A/C
Model type for K Series(R410A)**

PAC9041

PAC12041

PAC18041

PAC24041

Service Manual

2012

CONTENTS

Product Specification.....	1
Refrigeration Diagram.....	3
Introductions of Installation.....	6
Remote Controller Introductions.....	13
Brief Introduction for Usage.....	21
Wiring Diagram.....	27
Troubleshooting Guide.....	31
Exploded Views & Parts List.....	48

Chapter 1 Product Specification

1.1 Photo of Product

Indoor Unit For KP



Outdoor Unit

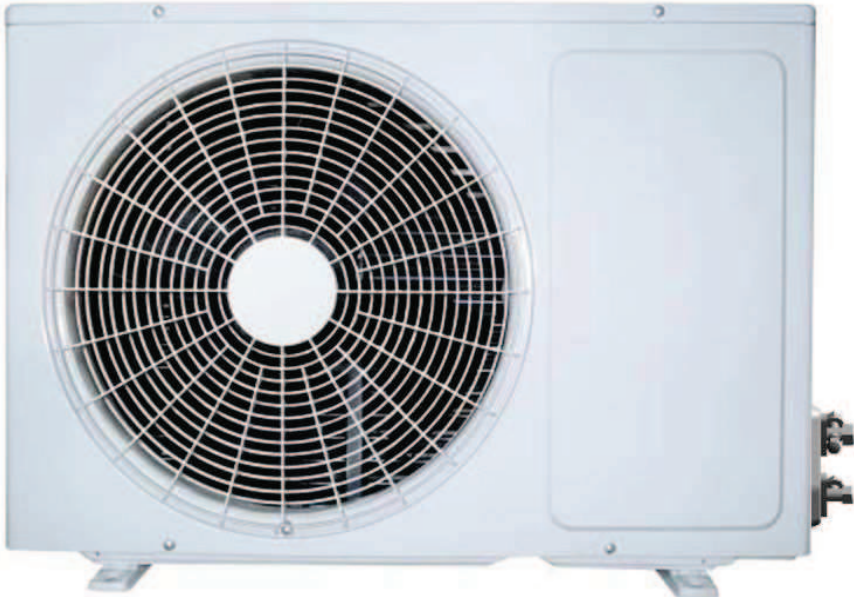

Reminder: All views here are for reference only, Specifications are subject to the physical product.

1.2 Outline

Indoor Unit



MODEL		9000BTU	12000BTU	18000BTU	24000BTU
W	mm	680	750	880	1080
D	mm	185	185	208	232
H	mm	255	255	280	300

Dimensions

Outdoor Unit

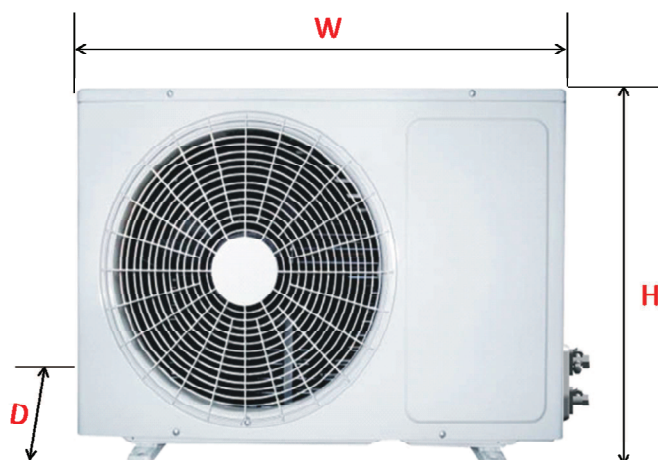

MODEL		9000BTU	12000BTU	18000BTU	24000BTU
W	mm	663	700	760	800
D	mm	254	225	260	300
H	mm	421	500	540	590

Chapter 2 Refrigeration Diagrams

2.1 Cooling Only

Cooling Mode

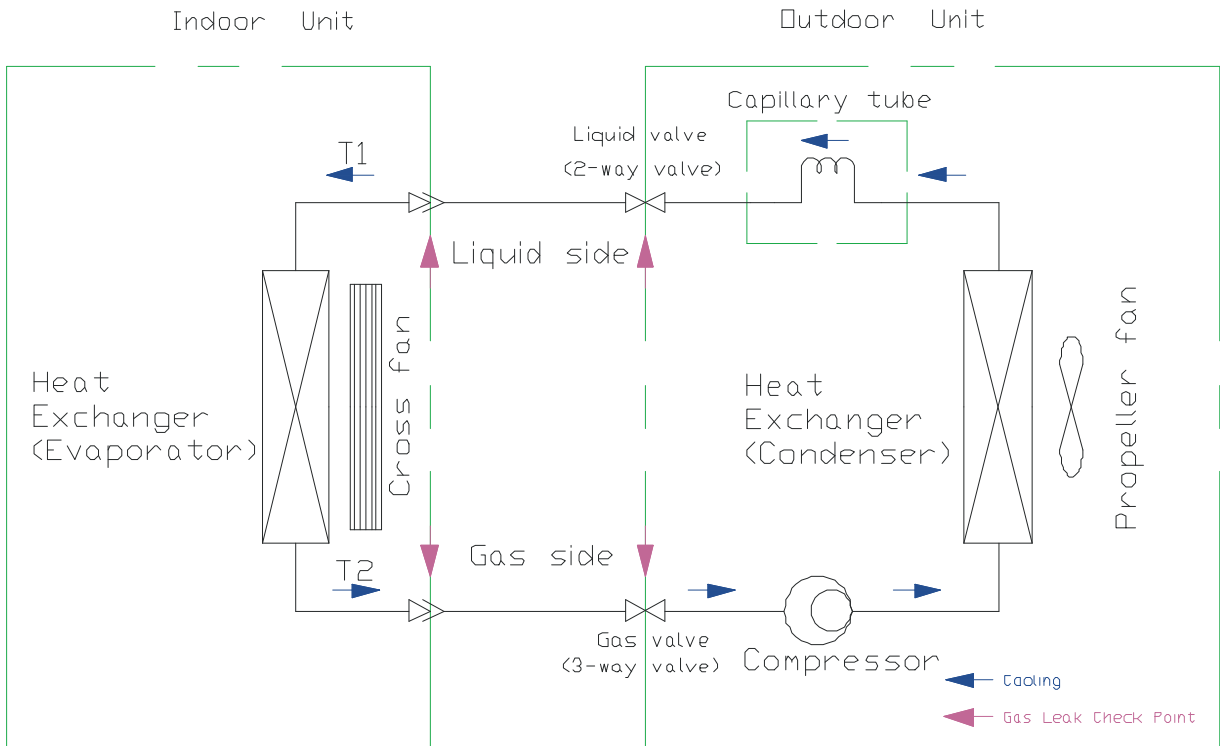

Cooling Cycle

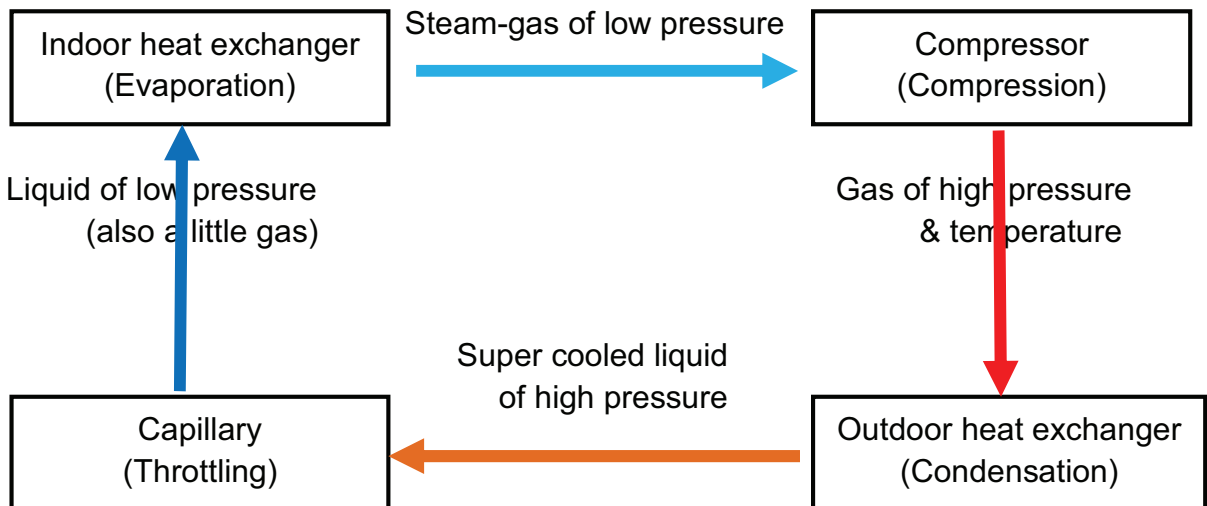

2.2 Cooling & Heating

Cooling Mode

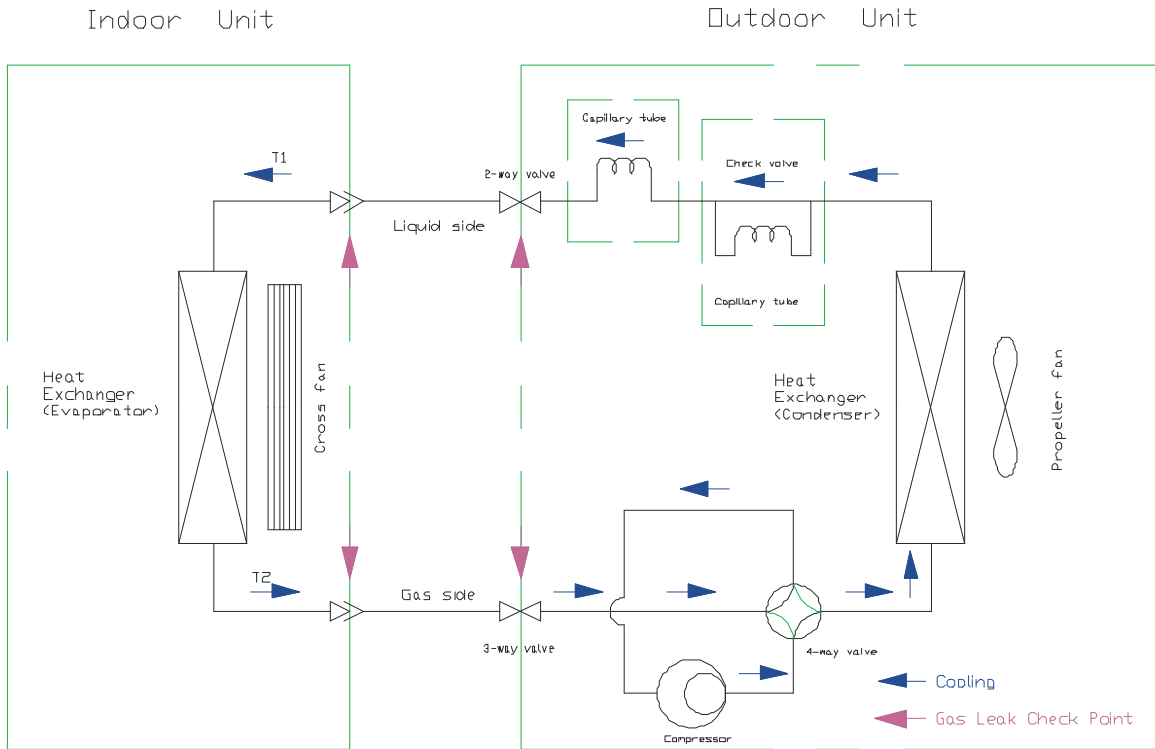

Cooling Cycle

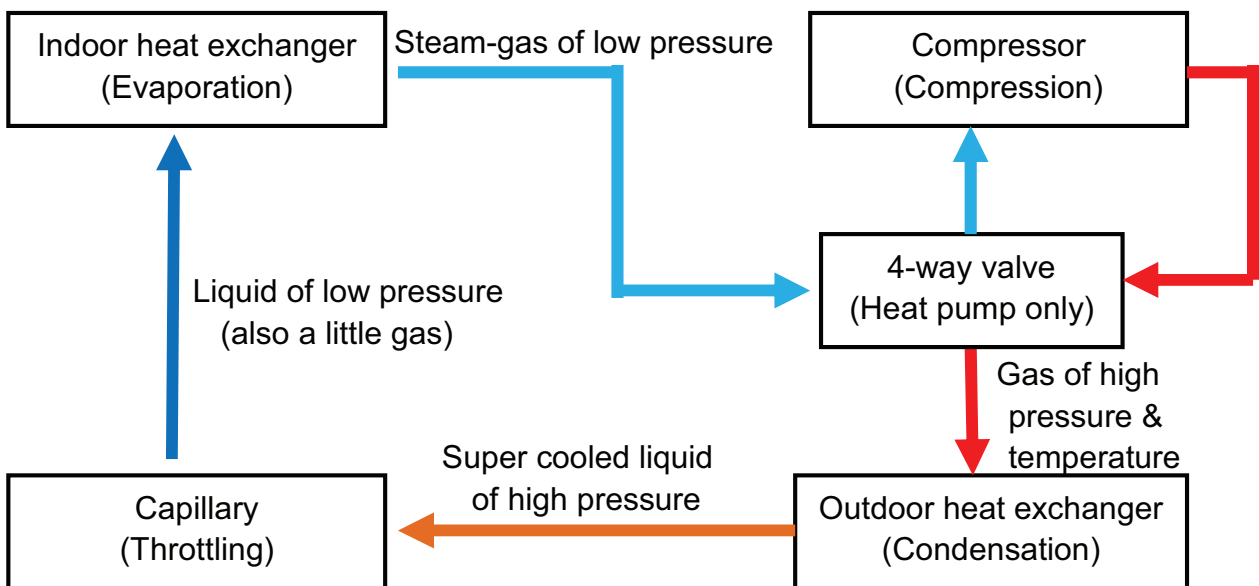

Heating Mode

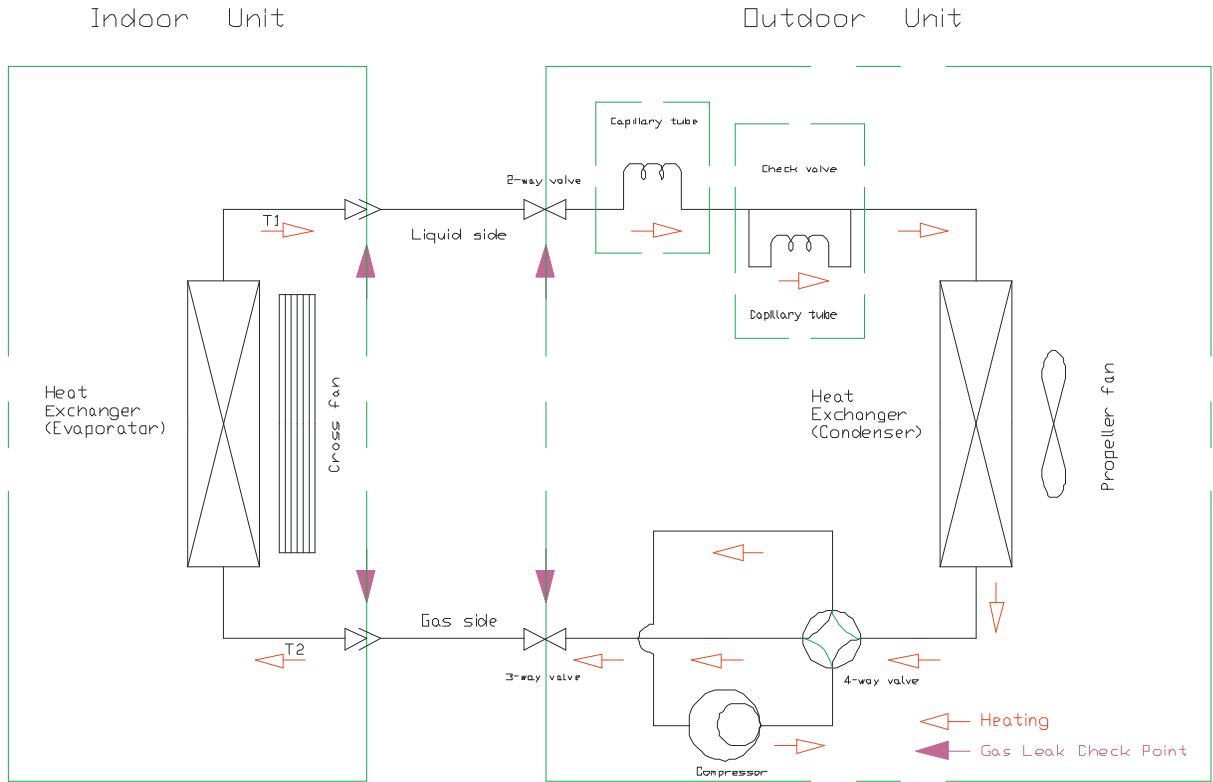

Heating Cycle

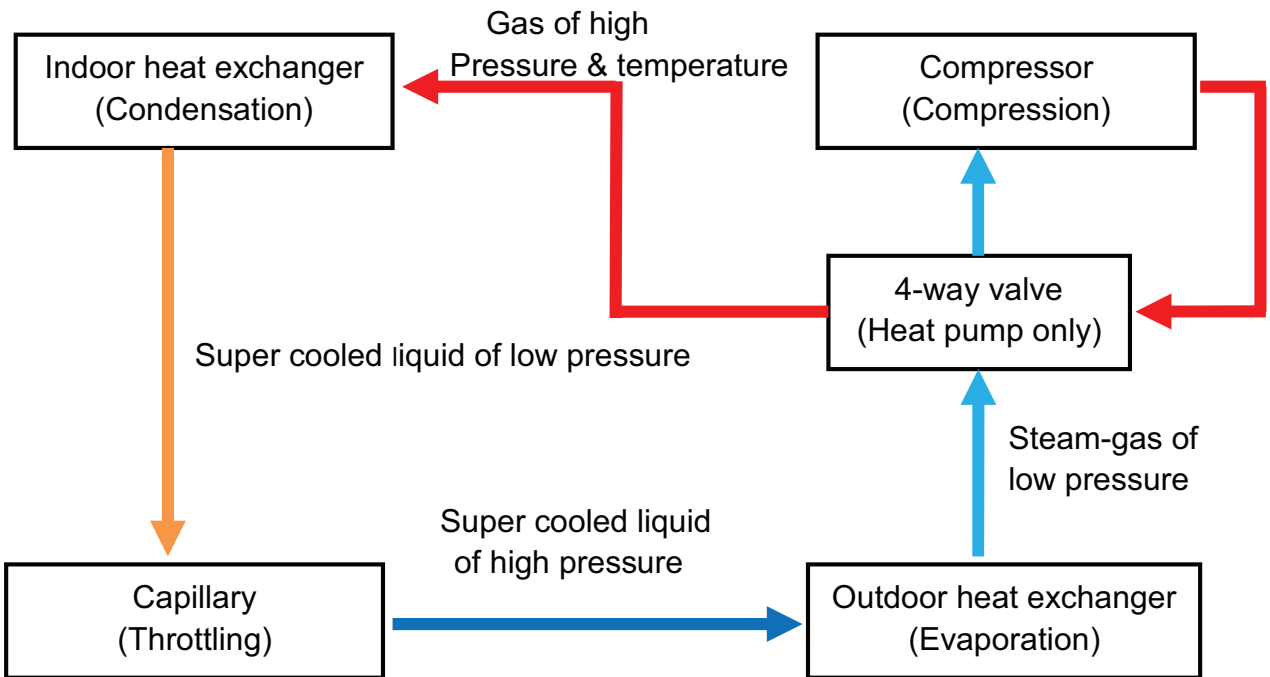

Chapter 3 Instructions of Installation

SPLIT TYPE WALL MOUNTED AIR-CONDITIONER INSTALLATION INSTRUCTIONS

The Installation Instructions is used to Split type wall mounted air-conditioner installation .

- ※ Please read the instructions carefully before installation of the air-conditioner.
- ※ The installation should be carried out by specialists.
- ※ installing the air-conditioner and connecting the pipe and wires must be strict to reference the instructions.
- ※ The machine power connections is Y.If the power wires is destoried,electrical performance should be carried out by electrical specialists .

Warning

- ※Installation is forbidden in the stairs ,the exists and the corridors in the building.
- ※Make sure that the distance between the support of outdoor unit and the ground is 2.5m.

Installation order: Selection of the installing position→Installation the air -conditioner→connecting the pipes and wires→Expelling the air in the pipes and the indoor unit→Testing

Selection of the installing position

Indoor Unit

- There is no heating and steaming source nearby.
- No obstacles for installing position nearby.
- Keep good air circulation.
- Convenient to adopt measures to reduce noises.
- Don't install them near the doorway.
- Make sure to have the distance specified in the picture between the ceiling, wall, furniture and other obstacles.
- 2 meters high above the floor.

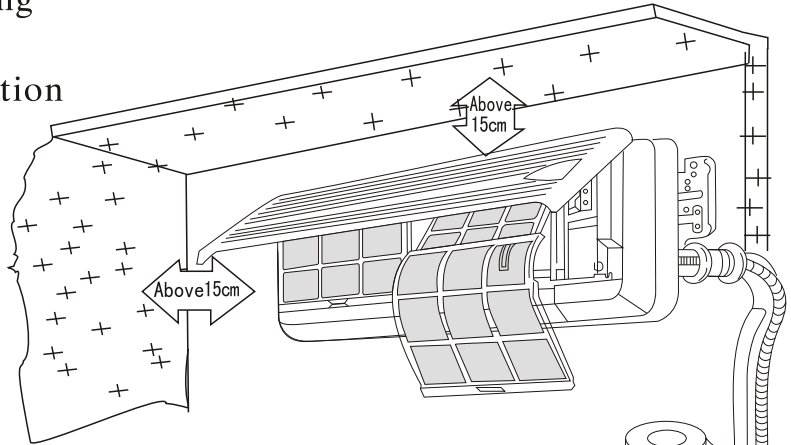

Outdoor Unit

- In case that you put up a canopy to protect it from rains and sunrays, pay attention not to cause any obstacles for the heating dispersion for the condenser.
- Don't grow animals or plants near the installation location for the cold and hot air out will affect them.
- Make sure to have the distance specified in the picture between ceiling, wall, furniture and other obstacles.
- Stay away from heating source and inflammable air.
- The installation base and supporting frame should be strong and secure. The machine should be at plane surface.

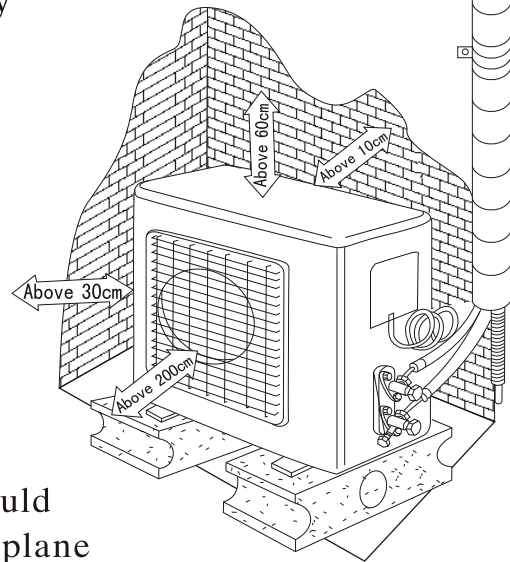

The distance between indoor and outdoor unit should be 5 meters and pipe length can go up to maximum 15 meters with additional refrigerant charge.

Max. Allowable Tubing Length at Shipment(m)	Limit of Tubing Length(m)	Limit of Elevation Difference H(m)	Requires Amount of Additional Refrigerant (g/m)	
			CC≤12000Btu	CC≥18000Btu
5	15	5	20	30

Installation of the Outdoor Unit

- The outdoor unit must be firmly fixed to avoid falling in the strong wind.
- Install on the cement base the drawing below.
- If it will be installed at seaside or at a place high above the ground and with strong wind, the AC should be installed against the wall to ensure the normal operation of the fan and the blocking plate should be used.
- If it will be installed in lift type, the structure of the mounting surface should be made of solid stick, cement or materials with equivalent strength, and be of enough bearing capacity. Otherwise, measures such as reinforcement, support or vibration damping should be adopted.

Outdoor Unit Size of Shape (mm)	A (mm)	B (mm)
663×254×421	431	278
700×225×500	458.5	262
760×260×540	539	287
800×300×590	540	326

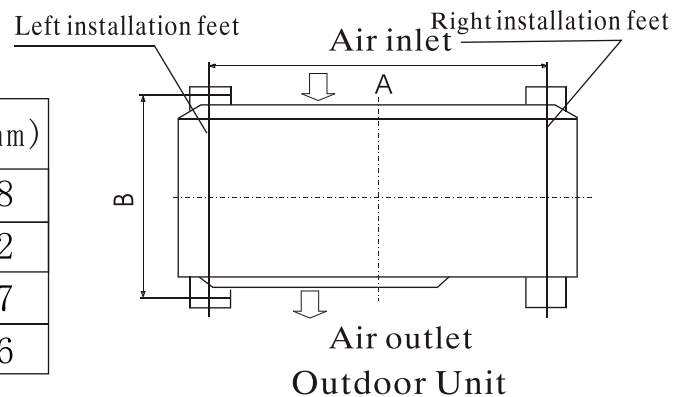

Installation of the Indoor Unit

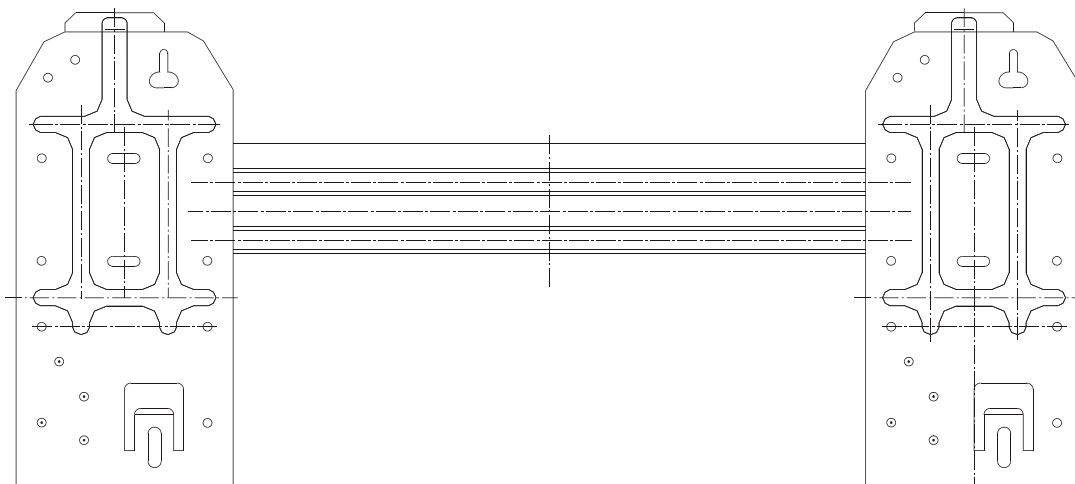

- First make changes to wall and make sure that is hard and secure. Using four “+” type screws to fasten the installation board onto the wall. Keep it water lever horizontal direction and perpendicular in vertical direction. Otherwise it might cause water drops when air-conditioner is running cooling operation.

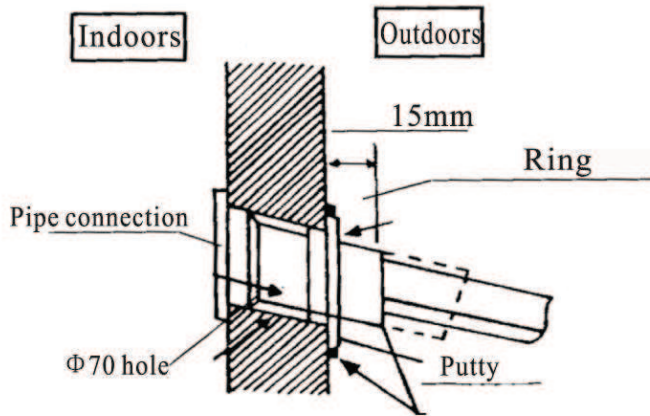

- Drilling 70mm diameter pipe hole at the left down or right down side of the installation board. The hole shall slant outward slightly.

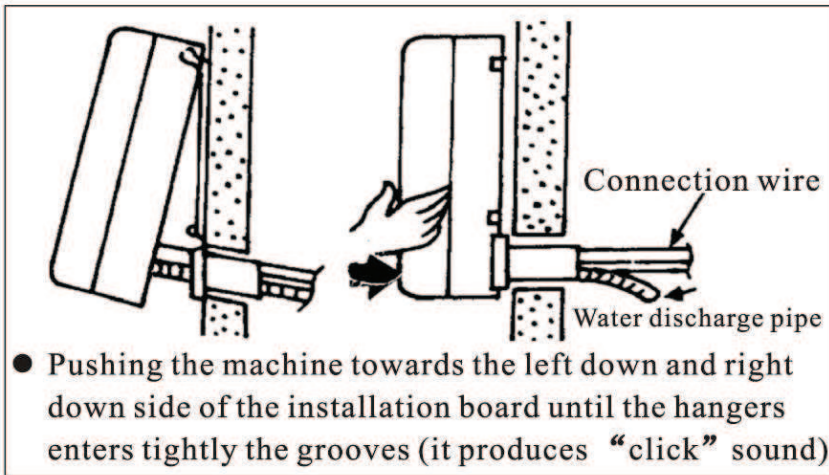

- Hang the indoor unit to the board and make sure the machine is in the middle of the board.

Check the water discharge

1. Take off the frame the unit cover.

Take off the front frame for maintenance according to the following steps:

- Turn perpendicular airflow direction handle from "I" to horizontal direction.
- As shown in the picture on the right, take off two covers from the front frame and then unfasten two fixture screws..
- Pull the front frame towards yourself and take it off.

In case that put the front frame back, turn the perpendicular airflow direction handle from "I" to horizontal, then proceed according to the third and the second steps.

You should check whether the front frame is firmly inside the fixture groove on the top.

2. Check the water discharge

- Put a cup of water into groove.
- Check whether the water flow through the water discharge hole.

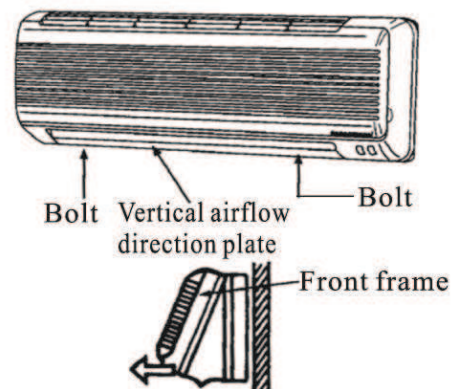

Pull down the front frame towards your and take off the front frame.

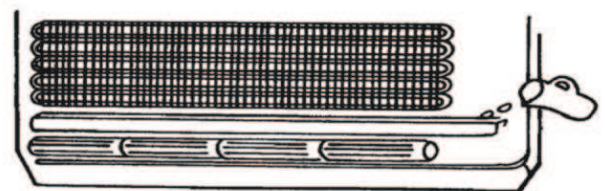

Pipe Connection

- Connect the pipe to the unit: point to the center of pipe and fasten the connection screw at first by hand and then by wrench until it is tightly fastened, The fastening direction is in the following picture.

The size of pipe	Torque
Liquid pipe $\Phi 6.35\text{mm}$	18N. m
Air pipe $\Phi 9.52\text{mm}$	42N. m
Air pipe $\Phi 12.7\text{mm}$	55N. m
Air pipe $\Phi 15.88\text{mm}$	75N. m

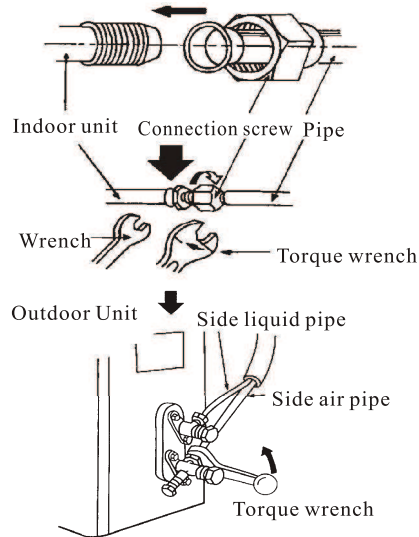

- Pointing towards the center of pipe, fasten the screw with strength.
- Wrench the screw in the end until you hear the “Click” sound.

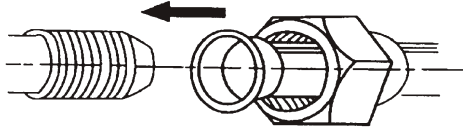

(Refer the direction to the picture)

The form of pipe

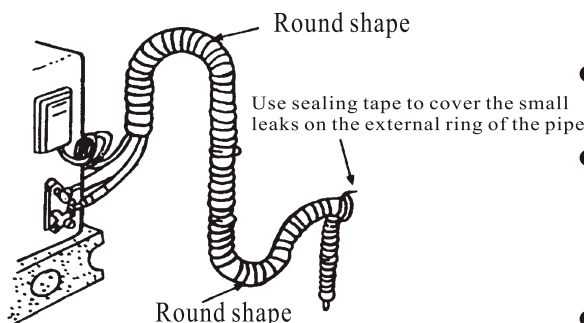
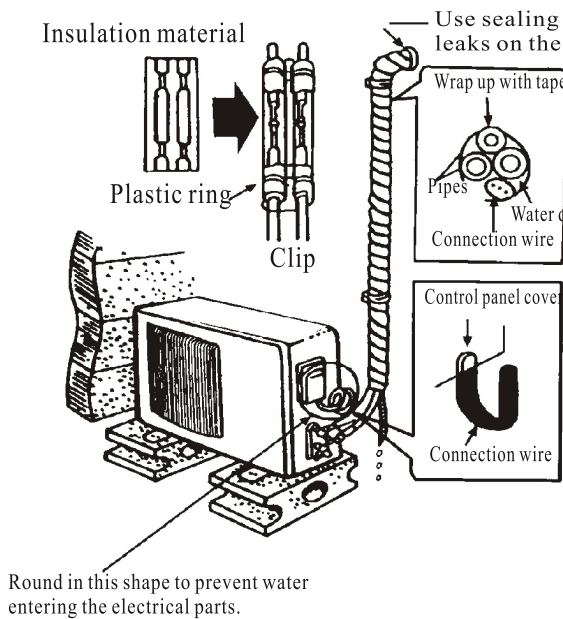

See the picture on the left

- Wrap up all pipe, water discharge and connection wire from top to below.
- Cover the connection parts with insulation material and fix them with two plastic rings.
- Wrap up the pipes with tape alongside the wall and fix them to the wall with clips. These steps are usually adopted when outdoor unit is installed below the indoor unit.
- In case that you want to have additional water discharge pipe, the end of pipe should be within certain distance towards to surface (don't let it under the water. Fix it onto the wall so it won't be swayed by the wind)
- Wrap the pipes and connection wire well from below to top.
- Wrap up the pipes that are rounded up by the wall corners in the way shown in the picture so it can prevent water entering the room.
- Use clips or other fixture to fasten the pipes to the walls.

Expelling the air in the pipes and the indoor unit

Expelling the air: humid air in the refrigerating system might cause trouble of compressor.

- Take off the cover from the stop valve and T-branch valve.
- Take off the auxiliary cover from the T-branch valve.
- Turn the stop valve rod anti-clock wise to an angle of 90 degree, keep it open for 8 seconds and close the valve.
- Check whether there is air leakage at all connection parts of pipes.
- Push the top rod of T-branch valve by hexagon wrench to expel air.
- Repeat the third and fifth steps.
- Open the stop and T-branch valve with a hexagon wrench to make the unit operate.
- There is no leakage allowed, please check all the piping connection parts. You must test the leakage, generally, it can be tested by soap water.

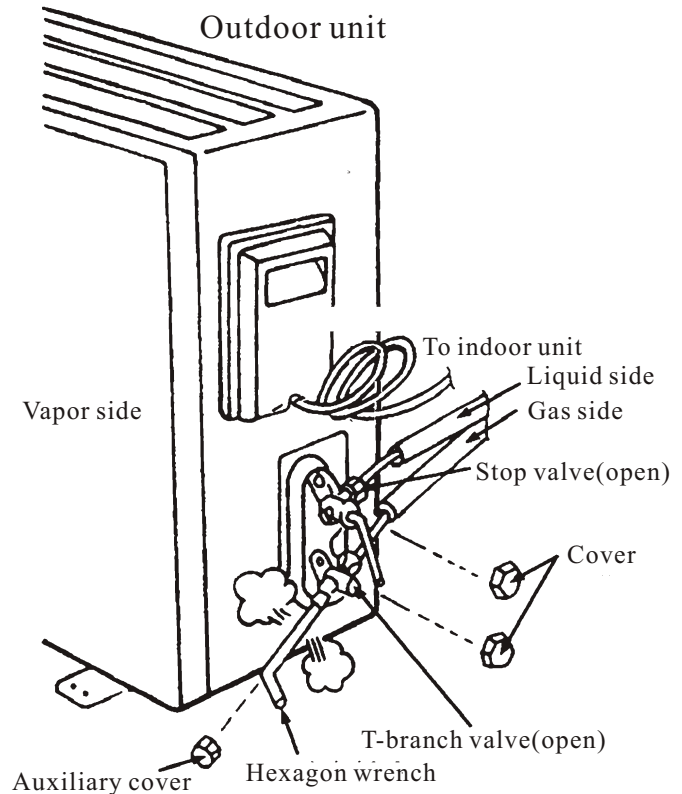

- **If the A/C is filled with R410a, make sure to discharge air and moisture remaining in the refrigerant system with a vacuum pump.**

(For method of using a manifold valve, refer to its operation manual.)

1. completely tighten the flare nuts, A, B, C, D, connect the manifold valve charge hose to a charge port of the low-pressure valve on the gas pipe side.
2. Connect the charge hose connection to the vacuum pump.
3. Fully open the handle Lo of the manifold valve.
4. Operate the vacuum pump to evacuate. After starting evacuation, slightly loose the flare nut of the Lo valve on the gas pipe side and check that the air is entering (Operation noise of the vacuum pump changes and a compound meter indicates 0 instead of minus.)
5. After the evacuation is complete, fully close the handle Lo of the manifold valve and stop the operation of the vacuum pump. Make evacuation for 15 minutes or more and check that compound meter indicates $-76\text{cmHg}(-1 \times 10^5\text{Pa})$.
6. turn the stem of the packed valve B about 45° counterclockwise for 6~7 seconds after the gas coming out, then tighten the flare nut again. Make suer the pressure display in the pressure indicator is a little higher than the atmosphere pressure.
7. Remove the charge hose from the Low pressure charge hose.
8. Fully open the packed valve stems B and A.
9. Securely tighten the cap of the packed valve.

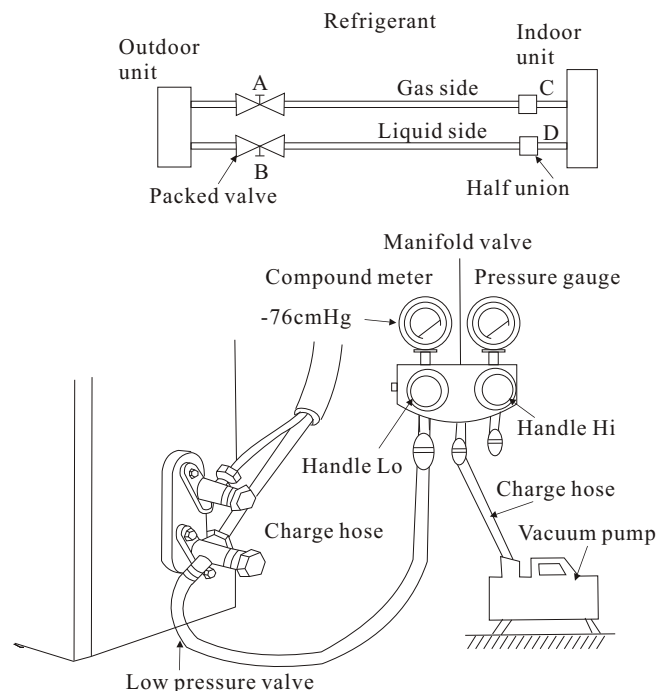

Electrical connection

- Unscrew the screw, take off the control panel cover from the unit.
- Connect the cable to their terminals according to their number.
- The grounded wire connection:
 1. loosen the grounded screw of electrical shelf.
 2. Connect the grounded wire with the grounded screw then setscrew in the “⊕” mark formerly.
- Fix the cable to the terminal board with fastening piece.
- Reinstall the cover with the screw.

NOTE:

- ※Don't reverse the power polarity.
- ※The wrong connection lead to the mal function of some electrical parts.
- ※Must fix the screw nail of the firmly wire, then drag the wire lightly, confirmation whether it's firmly.
- ※Must changed if the wire slide, the self-drive screw can't used to the electric connection.
- ※If there is a connector, connect it directly.

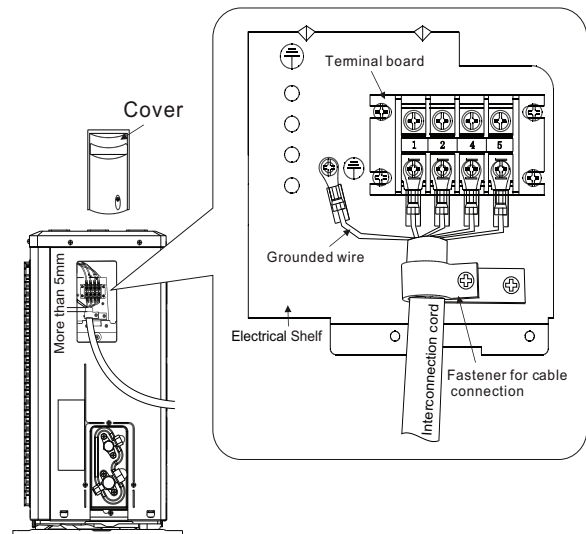

Cold wind Type
Terminal board for outdoor unit

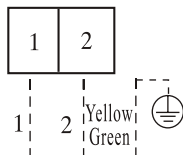

Temperature control wire connector
(only for heat pump type)

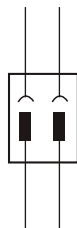

Heat-pump type
Terminal board for outdoor unit

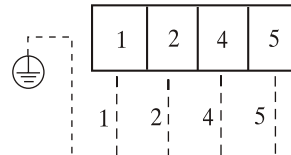

Compressor signal wire connector
(only for cooling pump type
6000W/7000W)

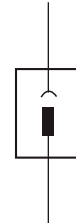

Compressor signal wire connector and
temperature control wire connector
(only for heat pump type 6000W/7000W)

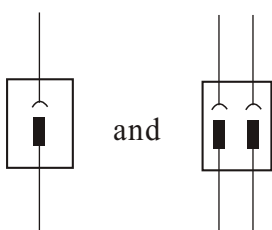

Single wire Double wires

Note:
Explanation for the power cord without plug (see below figure):

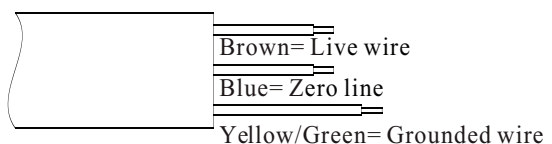

Chapter 4 Remote Controller Introductions

AIR-CONDITIONER REMOTE CONTROLLER INSTRUCTIONS

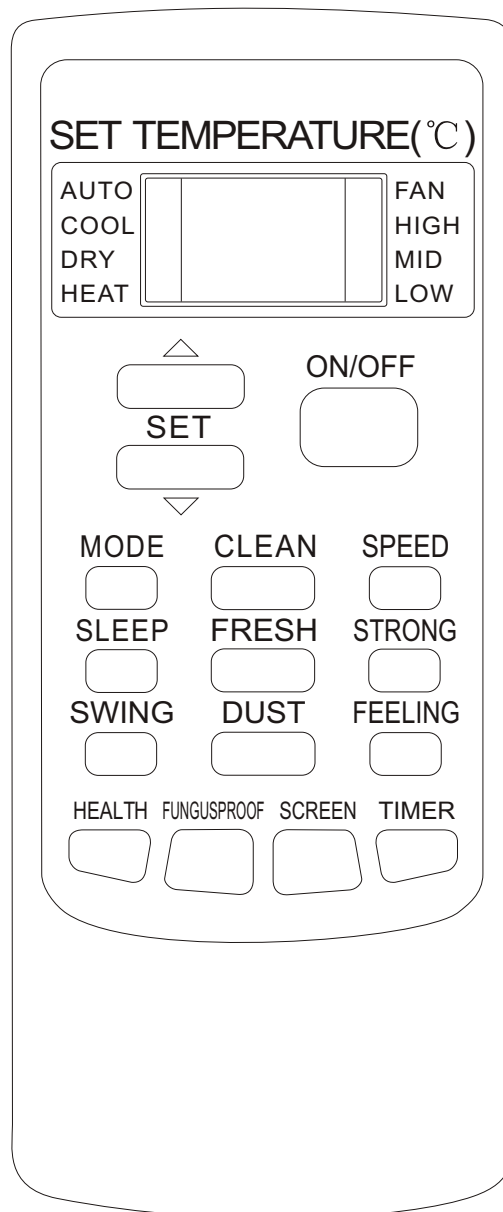

- Read this “instructions” carefully so that you can use the air-conditioner safely and correctly.
- Take good care of the “instructions” so that it can be referred to at any time.

Buttons description

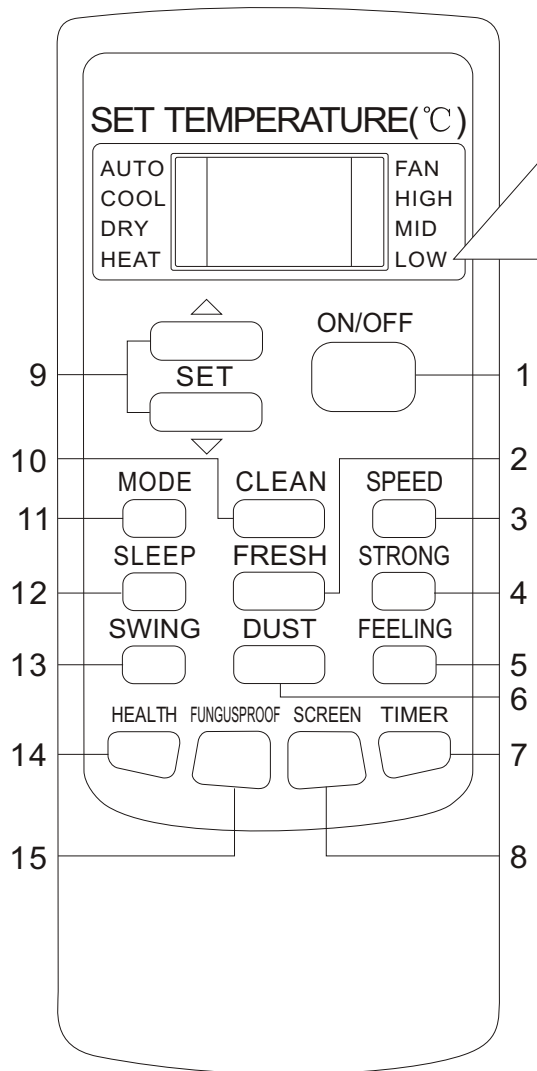

LCD displays instruction

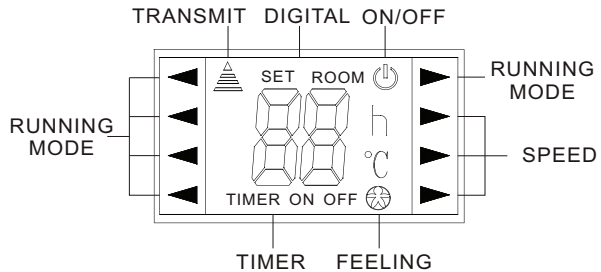

ON/OFF display:

when the remote controller is the on state, the LCD will be displays otherwise will not be display.

Digital display:

Under the state of normal working. It displays set temperature, while the feeling function is start. It will displays room temperature, and under the state of timer mode. It will displays set timer.

1. “ON/OFF” button

You can start the air-conditioner by pressing this button and stop its operation by pressing it again.

2. “FRESH” button

This button is invalidation.

3. “SPEED” button

You can select fan speed show as the follow:

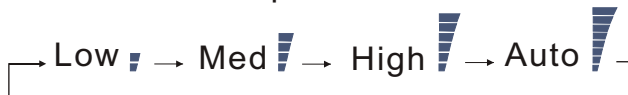

4. “STRONG” button

Only under the state of cooling or heating mode, press this button, the fan speed is adjusted to strong auto-matically and the LCD displays “high fan”, the “strong” function is started to reach the highest cooling or heating.

5. **“FEELING”** button

When it displays **“FEELING”** button:

Press this button can be used to set the feeling function. The LCD shows the actual room temperature when the function set and it shows the setting temperature when the function cancelled. This function is invalid when the appliance at the Fan mode.

6. **“DUST”** button

This button is invalidation.

7. **“TIMER”** button

Setting the “ON” timer time:

- a. When remote controller is at off state, press **“TIMER”** button, the LCD displays **“TIMER ON”** and the timer time, the range of setting time is 0.5h to 24h.
- b. You can press the **“△”** or **“▽”** button to adjust the timer time, each touch will be set time to increase or reduce 0.5h before 10 hours ago, after ten hours will be set time to increase or reduce 1h per pressing, to enables your required timer.
- c. Press **“TIMER”** button again, to set the timer on function.
- d. You can set another function to insure the suitable state after air conditioner turn on (including mode, temperature, swing, fan speed and etc). The LCD will displays all your setting and keep it, when the timer reach to the set time, the air conditioner will be working according to your set automatically.

Setting the “OFF” timer time:

- a. When remote controller is at on state, press **“TIMER”** button, the LCD displays **“TIMER OFF”** and the timer time, the range of setting time is 0.5h to 24h.
- b. You can press the **“△”** or **“▽”** button to adjust the timer time, each touch will be set time to increase or reduce 0.5h before 10 hours ago, after ten hours will be set time to increase or reduce 1h per pressing, to enables your required timer.
- c. Press **“TIMER”** button again, to set the timer off function.

8. **“SCREEN”** button

You can let the LCD displays working or not by pressing this button.

9. **“△”** or **“▽”** button

Press the **“+”** or **“-”** button, you can set the temperature range from 16°C to 32°C, Display will change as you touch the button.

10. **“CLEAN”** button

- a. When remote controller is at the off state, press **“clean”** button, the wind guiding bars turn to initial postions for cooling, the A/C runs **“clean”** function with max duration 35mins. The purpose of its function is to clean dust on evaporator and dry the inside water of evaporator and to prevent the evaporator going moldy due to water deposition and boasting strange smell.
- b. After setting **“clean”** function, press **“clean”** button again to cancel **“clean”** function or press **“ON/OFF”** button to cancel **“clean”** function and start A/C.
- c. The clean function will be no working after 35 minutes running working without any operation.

Note: “clean” function can be set in parallel with “time start” function; in this case , “time start” function will be executed after “clean” function.

11. **“MODE”** button

Which enables you to select different operation mode, after each pressing, the operation mode will be changed. It shows in the following display.

AUTO→COOL→DRY→HEAT→FAN→AUTO

Remark: cold wind type has no heating function.

12. **“SLEEP”** button

1. press the SLEEP button, the sleeping indicator light of indoor unit flashes on.
2. after the setting of sleeping mode, the cooling operation enables the set temperature to increase 1°C after 1 hour and another 1°C automatically after 1 hour.
3. after the setting of sleeping mode, the heating operation enables the set temperature to drop 2°C after 1 hour and another 2°C automatically after 1 hour.
4. the air-conditioner runs in sleeping mode for 7 hours and stops automatically.

Remark: press the MODE or ON/OFF button, the remote controller clears sleeping mode away.

13. **“SWING”** button

Press this button, the horizontal wind direction vanes can rotate automatically, when you have the desired vertical wind direction, press it again, the horizontal wind direction vanes will be stopped at the situation of your choice.

14. **“HEALTH”** button

Press this button, you can turn on or off the health function.

15. **“FUNGUSPROOF”** button

This A/C has special dry and anti-mold function which has “yes” or “no” two selections. This function is controlled by the remote controller under cooling, dry and auto (cooling and dry) modes, the horizontal wind guiding bars are at the initial position for cooling. The A/C runs under heating mode (the cooling only A/C only runs under fan mode), the internal fan runs for three minutes with weak wind before stop. The purpose of this function is to dry the inside of the evaporator and to prevent the evaporator from going mouldy due to water deposition and thus dispersing strange smell.

Note:

1. **This function has not been set in the factory. You may freely set and cancel this function. The setting method is: under “off” status of the A/C and the remote controller, point the remote controller toward the A/C and continuously press “FUNGUSPROOF” pushbutton for one time, the buzzer keep beeps five times again after five times beeps, indicating that this function is ready. In case this function has been set, unless the whole A/C is powered off or the function is manually cancelled, the A/C then has this function as a default;**
2. **To cancel the function: 1. Power off the whole A/C; 2. Under “off” status of the A/C and the remote controller, point the remote controller toward the A/C and continuously press “FUNGUSPROOF” pushbutton for one time, the buzzer keep beeps three times again after five times beeps, indicating that this function has been cancelled;**
3. **When this function is on, it is suggested not to restart the A/C before it is completely stop;**
4. **This function will not run in case of time stop or sleep stop.**

Usage

★ Fix batteries

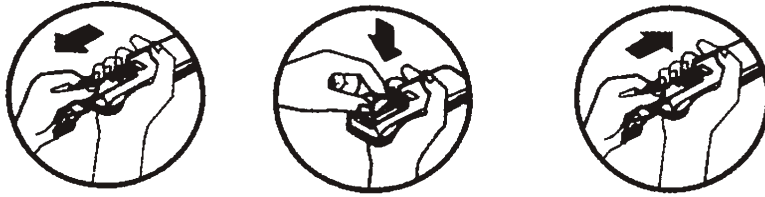

1. Slide open the cover according the direction indicated by arrowhead.
2. Put into two brand new batteries (7#), position the batteries to right electric poles (+&-).
3. Put back the cover.

★ Automatic operation mode

1. Press the MODE button, select the automatic operation mode.
2. Press the SPEED button, you can select fan speed. You can select fan speed from LOW, MID, HIGH, AUTO.
3. Press the ON/OFF button, the operation indicator is on, the air-conditioner starts to operate the automatic mode. Press the button again, the air-conditioner stops.

★ Cooling/Heating operation mode (cold wind type has no heating function)

1. Press the MODE button, select the Cooling or Heating operation mode.
2. Press the “ Δ ” or “ ∇ ” button, set the temperature, temperature can be set at 1 $^{\circ}$ C difference range from 16-32 $^{\circ}$ C.
3. Press the SPEED button, you can select fan speed. You can select fan speed from LOW, MID, HIGH, AUTO.
4. Press the ON/OFF button, the operation indicator is on, the air-conditioner starts to operate the automatic mode. Press the button again, the air-conditioner stops.

★ Fan operation mode

1. Press the MODE button, select the Cooling or Heating operation mode.
2. Press the SPEED button, you can select fan speed. You can select fan speed from LOW, MID, HIGH.
3. Press the ON/OFF button, the operation indicator is on, the air-conditioner starts to operate the automatic mode. Press the button again, the air-conditioner stops.

Remark: In the circulation operation mode, to set the temperature is noneffective.

★ Drying operation mode

1. Press the MODE button, select the Dry operation mode.
2. Press the “ Δ ” or “ ∇ ” button, set the temperature, temperature can be set at 1 $^{\circ}$ C difference range from 16-32 $^{\circ}$ C.
3. Press the SPEED button, you can select fan speed. You can select fan speed from LOW, MID, HIGH, AUTO.
4. Press the ON/OFF button, the operation indicator is on, the air-conditioner starts to operate the automatic mode. Press the button again, the air-conditioner stops.

★ Night Luminous Function of Remote Controller(Only the remote controller with this function can be used)

For your convenient use of the remote controller in the darkness without any lighting, this remote controller has blue background light and luminous pushbuttons. Function at you press on any of the pushbutton, the background light will immediately release soft light so that you are easy to operate the remote controller. If you do not operate the controller within 10 seconds, the background light will automatically disappear.

Note:

All the figures above are the displays after being initially electrified or re-electrified after power off. In actual operations, the remote controller screen displays related items only.

Attention

1. Aim the remote controller towards the receiver on the air-conditioner.
2. The remote controller should be within 8 meters away from the receiver.
3. No obstacles between the remote controller and receiver.
4. Do not drop or throw the remote controller.
5. Do not put the remote controller under the forceful sunrays or heating facilities and other heating sources.
6. Use two 7# batteries, do not use the electric batteries.
7. Take the batteries out of remote controller before stop its using for long.
8. When the noise of transmitting signal can't be heard indoor unit or the transmission symbol on the display screen doesn't flare, batteries need be replaced.
9. If reset phenomenon occurs on pressing the button of the remote controller, the electric quantity is deficient and new batteries need to be substituted.
10. The waste battery should be disposed properly.

Name of Each Part

Indoor Unit

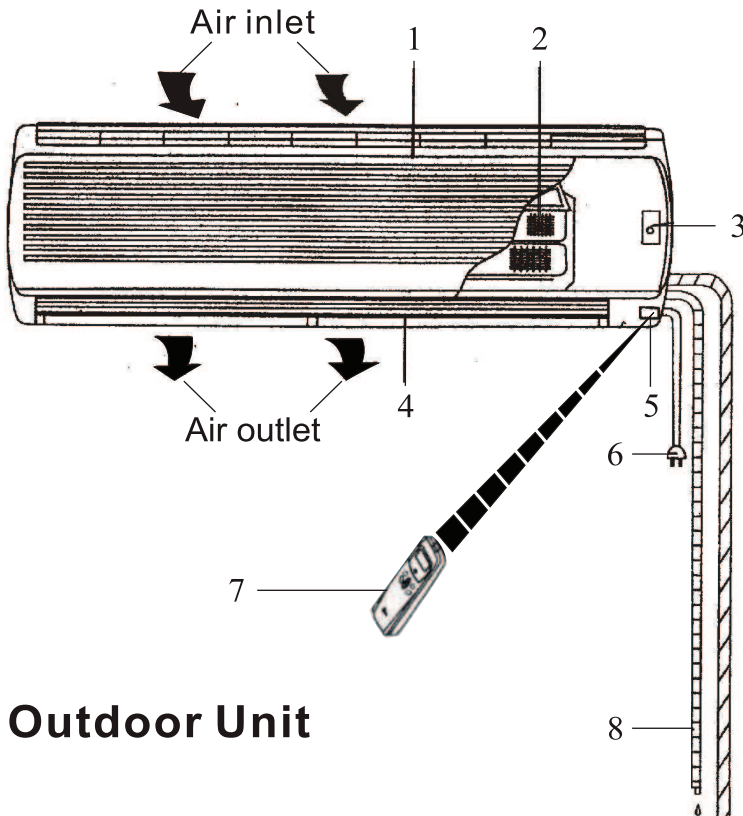

Indoor Unit

- 1、 Front panel
- 2、 Air filter
- 3、 Handling switch
- 4、 Louver
- 5、 Signal receptor
- 6、 Power plug
- 7、 Remote controller
- 8、 Drain hose
- 9、 Refrigerant gas/
liquid piping

Outdoor Unit

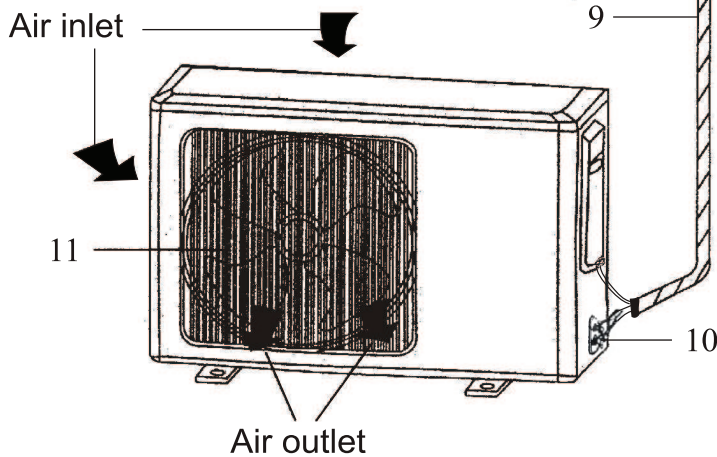

Outdoor Unit

- 10、 Cut-off valve
- 11、 Air outlet cover

Note:

All picture in this manual are for explanation purpose only. They may be slightly different from their conditioneryou purchased(depend on model)

Operation

★ Remote controller operation

See “*air conditioner remote controller instruction*”

★ Manual operation

☆ Manual operation

When the remote controller does not work or can not be found, please follow these steps:

- ① As the unit is operating, you can press the “Auto button” to stop operating.
- ② As the unit is stopping, you can press the “Auto button” to start operating.

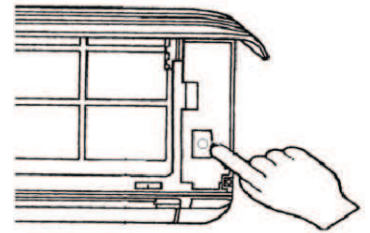

☆ Adjusting air flow direction

1. Adjusting horizontal air flow manually.

Use your hands to move the vertical airflow vane and change the horizontal wind direction.

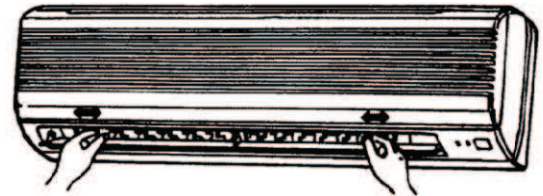

⚠ Note:

Adjust the horizontal air flow direction before the air-conditioner starts. Don't insert your finger into air intake or outlet vents when the air-conditioner is operating.

2. Adjusting vertical air flow direction (up-down)

Refer to “*air conditioner remote controller instruction*” for how to adjust vertical airflow direction through adjusting the horizontal airflow vane by remote controller.

⚠ Note:

- Adjust the vertical air flow direction by remote controller. When you adjust the horizontal airflow vane by hand, the machine may cause problem.
- Manual operation can be used temporarily in case you can not use remote controller or its batteries are exhausted.
- When the air-conditioner stops, the horizontal wind vane will close the wind outlet of air conditioner.

Chapter 5 Brief Introduction for Usage

Safety Precautions

Incorrect operation due to ignoring instruction will cause harm or damage. The seriousness is classified by the following indications

WARNING This symbol indicates the possibility of death or serious injury.

CAUTION This symbol indicates the possibility of injury or damage to properties only.

WARNING

- **The power plug must be inserted tightly.**

Otherwise, it can cause electric shock or overheating, even fire.



- **Don't destroy the power cord or use an unspecified one.**

It can cause overheating or fire.



⚠ **The power cord must be replaced and changed by specialists.**

- **Don't pull the power plug to pull out the power cord.**

The damage of power cord will cause serious electric shock.



- **Don't install air conditioner in a place where there is flammable gas or liquid.**

It may cause fire.

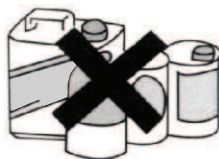

- **Don't touch the swinging wind vanes.**

It may clamp your finger and damage the driving parts of the wind vanes.



- **The main power switch should be placed where is unavailable for child to prevent the child from the danger of electric shock.**

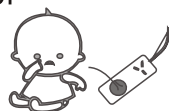

- **Don't pull out the power plug during operating.**

It can cause electric shock or fire.



- **Don't use longer power lines and don't share the socket with other appliance.**



- **Don't operate the air conditioner with wet hands.**

It will cause electric shock.



- **Don't put a finger, a rod or other object into the air outlet or inlet.**

As a fan is rotating at a high speed, it will cause injury.



- **Don't attempt to repair the air conditioner by yourself.**

You may be hurt or cause further malfunctions.



- **Stop operation and close the windows in storm or hurricane. Operation with windows opened may cause electric shock.**

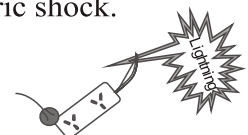

- Take care not let the remote control and the indoor unit watered or being too wet, or may short circuit even caused fire



- Children should be supervised to ensure that they do not play with the appliance. This appliance is not intended for use by persons (including children) with reduced physical, sensory or mental capabilities, or lack of experience and knowledge, unless they have been given supervision or instruction concerning use of the appliance by a person responsible for their safety .



- Cut off the main power switch when not using the unit for a long time. Otherwise, it may cause product failure or fire.

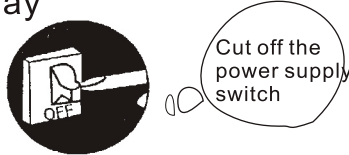

- An earth leakage breaker with rated capacity must be installed to avoid possible electric shocks.



- Don't use liquid or corrosive detergent clean the appliance and don't splash water or other liquid onto it , otherwise, it may damage the plastic components, even cause electric shock.

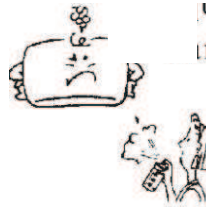

CAUTION

- Don't install the indoor unit under sunshine directly.



- Close the windows and doors, otherwise, the cooling or heating capacity will be weakened.

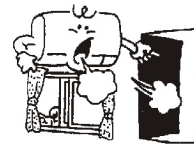

- Don't block air inlet or air outlet, otherwise, the cooling or heating capacity will be weakened , even cause system stop operating.



- If the air filter is very dirty, the cooling or heating capacity will be weakened. Please clean their filter regularly .



- Don't apply the cold air to the body for a long time. It will deteriorate your physical conditions and cause health problems.



- It was prohibited to stand or put things onto the top of the outdoor, to avoid drop or damage

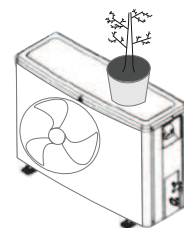

Care and Maintenance

★ Cleaning

☆ Cleaning the indoor unit

1. Turn off the air-conditioner and remove the electrical plug from the outlet.
2. Wipe the indoor unit with dry cloth or wet cloth which is dipped by cold water.

⚠ Note :

- Don't use water above 45°C to wash the panel, or it could cause deformation or depigment.
- Don't use thinner, polishing powder, benzene and other volatile chemicals.

☆ Cleaning air filter

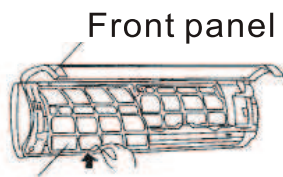

Air filter

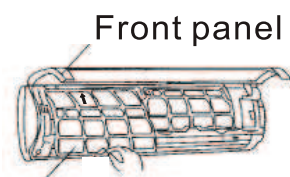

Air filter

1. Raise up the front panel of indoor unit until it suddenly stop, then raise up the protruded part of air filter, and then take it out.
2. Use a vacuum cleaner or wash them with water, then dry it in the shade.
3. Reinsert the air filter into the indoor unit until being entirely fixed, then close the front panel.

★ Maintenance

1. Select "FAN" operation mode, make the air conditioner run a long time to dry.



2. Turn off the air conditioner and cut off the power supply .



3. Take out the batteries from the remote controller.

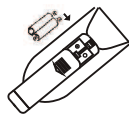

4. Clean air filters and other parts.

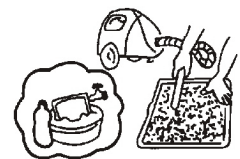

Troubleshooting

Check the following before requesting on service centre if the malfunction occurs.

Phenomenon	Trouble shooting
Air conditioner dose not operate atall	<ul style="list-style-type: none"> ● Has the power been shut down? ● Is the wiring loose? ● Is the voltage higher than 264V or lower than 198V? ● Is the fuse burnt? ● Does it reach the set time for start up?

Notices

To prevent injury and property damage, Please pay attention to these following before operating the air conditioner.

★ Checking before operation

1. Make sure that the earth wire is connected safely and reliably.
2. Make sure the filter net is properly fixed.
3. Make sure that air outlet and inlet are not blocked.
4. Please clean the filter before starting the air-conditioner referring to page to 6 “Cleaning” for how to operate.
5. Check to see whether the outdoor install bracket is damage. if yes, please contact our Service center locally.

★ Safety tips

1. Installation should always be carried out by specialist. The customers should not install the air-conditioner by themselves. Otherwise, it may cause damage or injury.
2. In order to use the air conditioner properly, please refer to its working temperature range. Otherwise, indoor unit automatic protection function may be activated, cooling or heating efficiency will be weakened.

Working temperature range

Cooling	Indoor	Maximum:	DB/WB	32°C/23°C
		Minimum:	DB/WB	21°C/15°C
	Outdoor	Maximum:	DB/WB	43°C/26°C
		Minimum:	DB/WB	21°C/15°C
Heating	Indoor	Maximum:	DB/WB	27°C-
		Minimum:	DB/WB	20°C-
	Outdoor	Maximum:	DB/WB	24°C/18°C
		Minimum:	DB/WB	-5°C/-6°C

1. Set the suitable temperature, especially there are old people, children and patients in the room. Generally, keep the temperature difference for 5°C between the inside and outside.
2. In case that the unit occurs closing down due to the severe interference from outer environments such as mobile phone, please cut off the plug and plug in to restart the air conditioner after several seconds.
3. Never expose animals or plants to direct air flow, and adjust the air flow to avoid air blowing directly at people.
4. It is forbidden to let the air conditioner blow wind to the cookers, or it may effect the normal cooking and even cause danger!

Phenomenon	Troubleshooting
Remote controller is not available	<ul style="list-style-type: none"> ● Is the remote controller out of effective distance to the indoor unit? ● Is the battery exhausted? ● Are there any obstructions between the controller and the signal receptor?
Cooling (Heating) efficiency is not good	<ul style="list-style-type: none"> ● Is the setting temperature suitable? ● Is the air inlet or outlet obstructed? ● Are air filter dirty? ● Is indoor fan speed set at low speed? ● Is there any heat source in your room?
Indoor unit does not operate immediately when the air conditioner is restarted	Once the air conditioner is stopped, it will not operate in approximately 3 minutes to protect itself.
There is unusual smell blowing from the outlet after operation is started.	This is caused by the odour in the room permeated from building material, furniture, or smoke.
Sound of water flow can be heard during cooling operation	This is caused by the refrigerant flowing inside the unit.
Mist is emitted during cooling operation.	Because the air of the room is cooled down rapidly by the cold wind and it looks like the fog.
Mist is emitted during heating operation.	This generate due to moisture in defrosting process.
Low noise can be heard during operation	<ul style="list-style-type: none"> ● A low hissing sound is caused by the refrigerant flowing. ● A low squeak sound is caused by the deformation of plastic due to temperature.

In case the following situation, please immediately stop all operations and cut off the power supply, then contact with service centre

- The fuse and switch often breaks.
- Carelessly splash water or something into air conditioner.
- Unusual noise can be heard during operation.
- Electrical wiring and power plug are very hot.
- Wind blowing from the outlet smells terrible during operation.
- The Run light or other display flashes rapidly and keeps flashing after replugging.

Installation Guide

★ Guide for customer

- The installation must be done by professional referring to the “*Installation instructions*” .
- The wiring must be done by qualified electrician according to the electrical safety requirements.
- The customer should have a qualified power supply which coincides with the tag of air conditioner, the normal voltage should be in the range of 90-10% of its rated voltage.
- The air conditioner must be well grounded, the switch of the main power of air-conditioner must be reliably grounded.
- If your air conditioner is not fitted with a supply cord and a plug, an all-pole switch must be installed in the fixed wiring and the distance between contacts should be no less than 3.0 mm.
- If your air conditioner is permanently connected to the fixed wiring and have a leakage current that may exceed 10 mA, leakage protector must be installed in the fixed wiring, operating current of which shall not exceed 30 mA.

★ Notices

- The air conditioner must be installed on well strong supporter.
- The appliance shall be installed in accordance with national wiring regulations.
- Fix the machine firmly, otherwise it will produce abnormal noise and vibration.
- Install the outdoor unit in the place where it wouldn't disturb your neighbour.
- The method of connection of the appliance to the electrical supply and interconnection of separate components, please see the electric connection elements chart which stick on the machine.

WEEE Warning

Meaning of crossed out wheeled dustbin:

Do not dispose of electrical appliances as unsorted municipal waste, use separate collection facilities.

Contact your local government for information regarding the collection systems available.

If electrical appliances are disposed of in landfills or dumps, hazardous substances can leak into the groundwater and get into the food chain, damaging your health and well-being.

When replacing old appliances with new ones, the retailer is legally obligated to take back your old appliance for disposals at least free of charge.

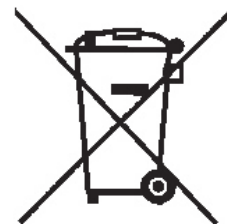

Chapter 6 Wiring Diagram

6.1 Electric chart for 09/12/18K/12K(115V)(Non inverter)

Indoor unit

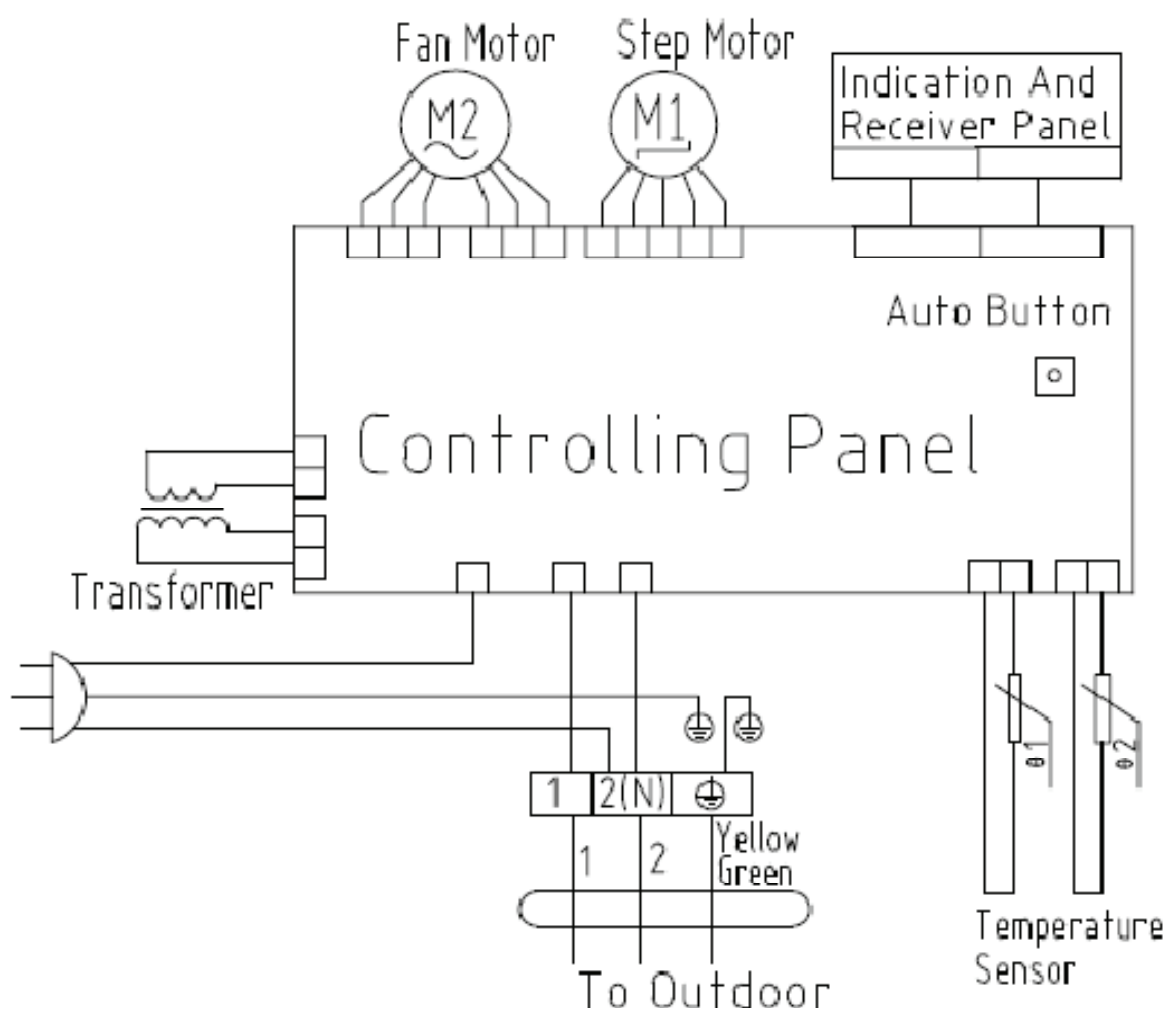

Outdoor unit

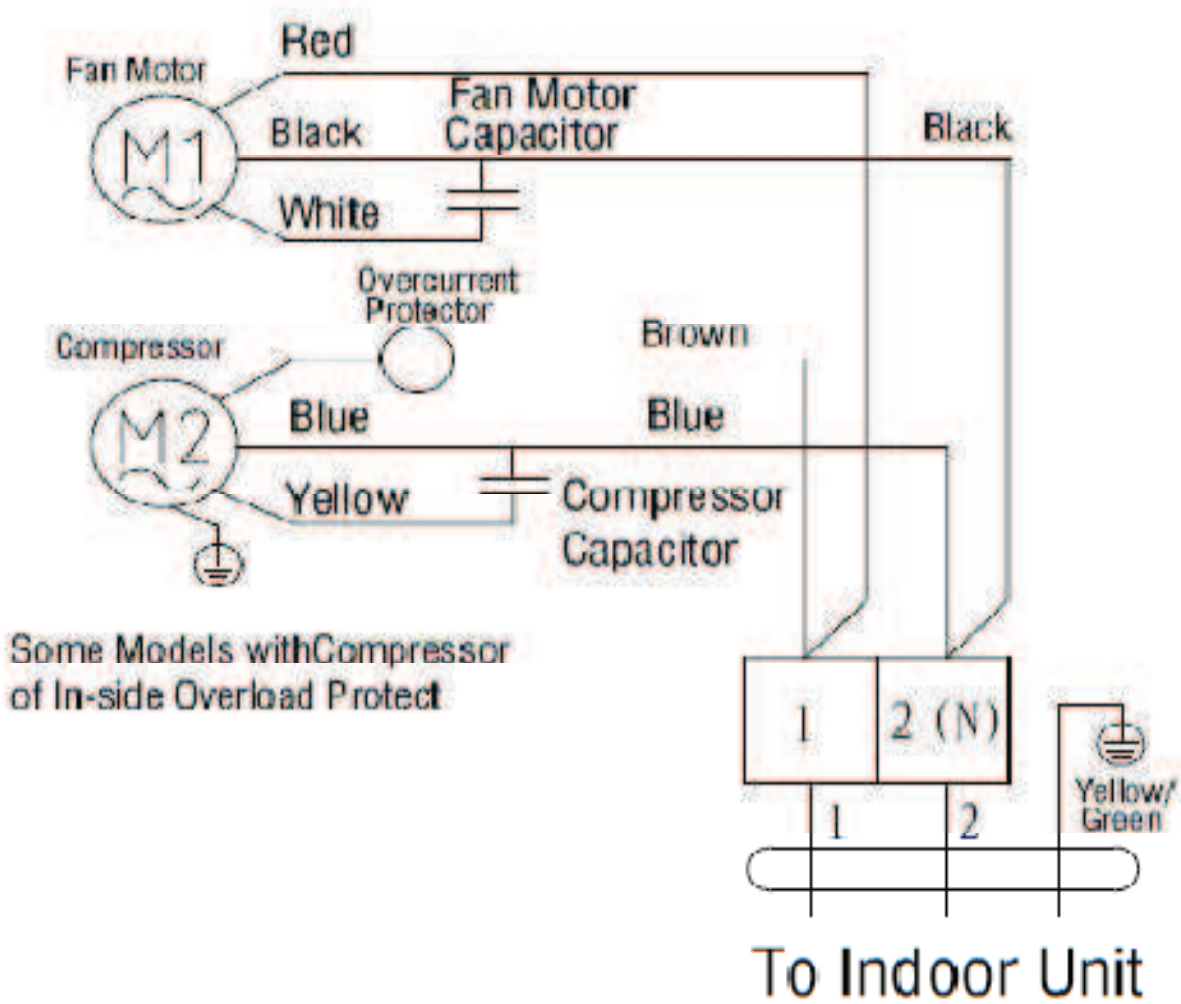

6.2 Electric chart for 24K(Non inverter)

Indoor unit

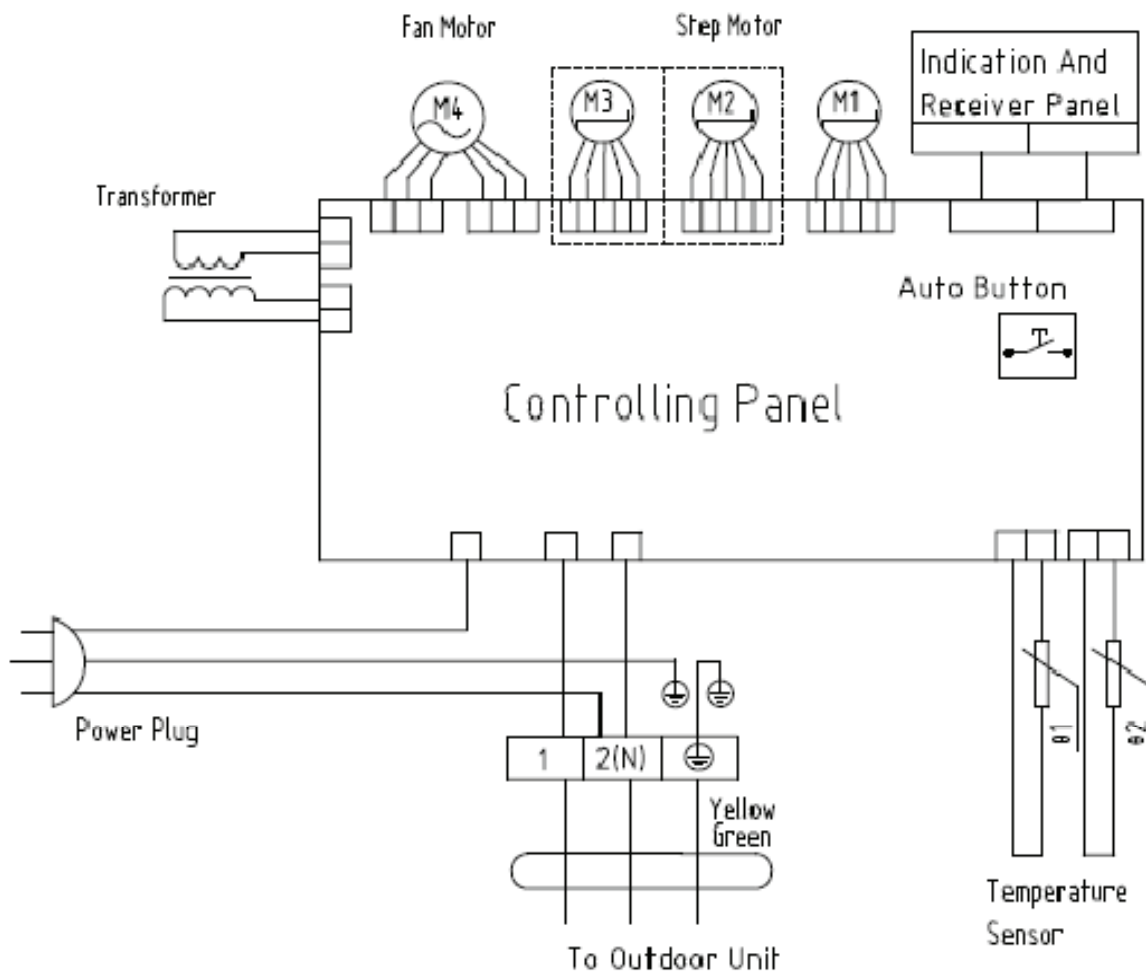

Outdoor unit

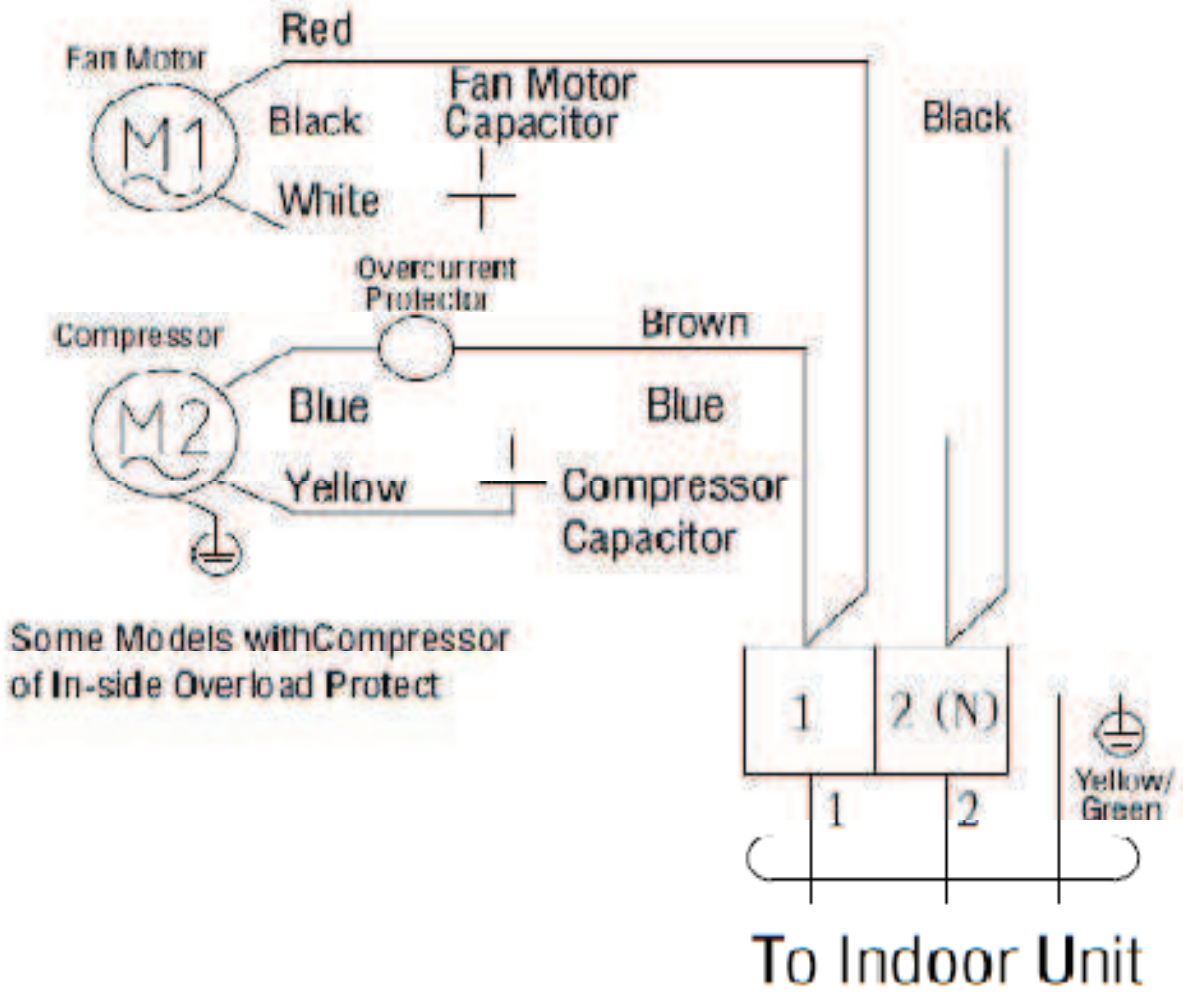

Chapter 7 Troubleshooting Guide

7.1 Error Code

No.	Error Code	Problem
1	E1	Temperature sensor of air intake fault
2	E2	Temperature sensor of outdoor coil fault
3	E3	Temperature sensor of indoor coil fault
4	E4	PG motor of indoor unit feedback fault

7.2 Troubleshooting Guide for 09-12K

1. The Foremost Inspecting Items

(1)The input voltage must be within +10% tolerance of the rated Voltage. If it is not the case, the air-conditioner will probably not work normally.

(2)Check the connecting cord between indoor unit and outdoor unit to see if it is properly connected. The connecting must be done according to the wiring diagram, please also notice that even different models may have the connecting cord of the same specification.

Please check if the marks at the connecting terminal and the marks on the cord can match, otherwise, the air-conditioner will not work normally.

(3)If the following phenomena are found, the problem is not from the air-conditioner itself.

NO.	Problems	Causes
1	The motor is heard operating but the air-conditioner dose not work when the indoor unit is powered on	Since the air-conditioner is powered on, it will come to working condition as long as you press the ON/OFF button of the remote control and the Signal is well received.
2	The compressor stops running but the indoor fan motor keeps working when it is at cooling mode with the indoor temperature higher than set temperature.	If you turn off the air-conditioner and restart it immediately, it will return to normal in 3 minutes, after that, the air-conditioner will automatically adjust the indoor fan speed to what you set.
3	The compressor works discontinuously at dehumidifying mode.	The air-conditioner will automatically control the working of the compressor according to the inside temperature
4	The air-conditioner does not work while the LED display is on.	The TIMER is set with the air-conditioner; it will be in hold on condition. If the TIMER setting is cancelled, the air-conditioner will return to normal working condition
5	The compressor works discontinuously at cooling and dehumidifying mode, and the indoor fan motor slows down.	The compressor stops internally or the fan motor slows down to prevent the indoor heat exchanger from being frozen.

2. No Power Display

(1) Items

- a) Check if the input voltage is correct?
- b) Check if the AC power supply connecting is correct?
- c) Check if the output voltage of the manostat L7805 (IC2) is correct?

(2) Trouble shooting procedure

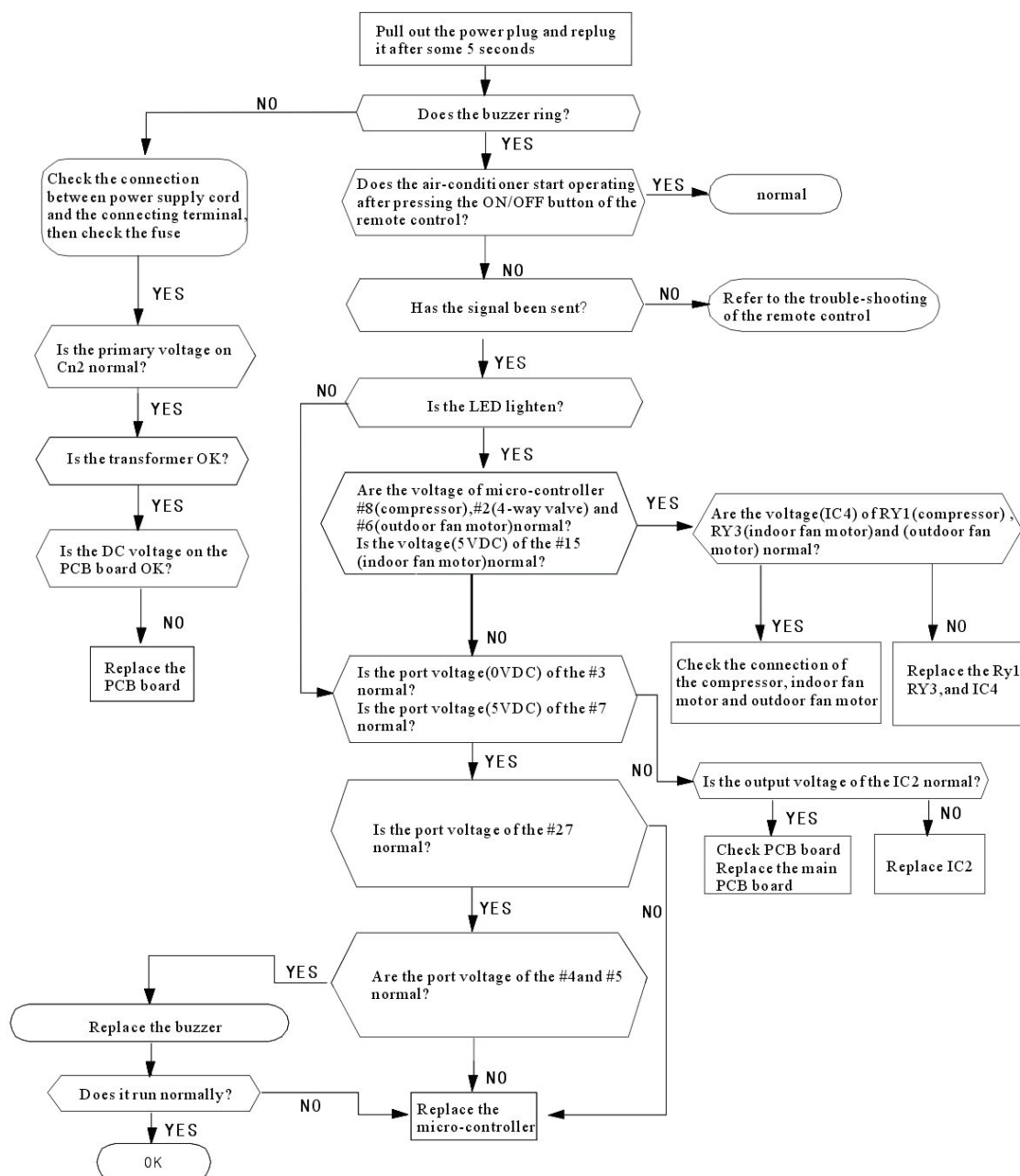

3. The Indoor Fan Motor Does Not Work

(1) Items

- a) Check if the indoor fan motor is connected correctly to the connector (CN8)?
- b) Check if the AC input voltage is correct?
- c) Check if the IC of indoor fan motor is connected correctly to the connector (CN2)?

d) Check if the capacity of indoor fan motor is connected correctly to the connector (CN8)?

(2) Trouble shooting procedure

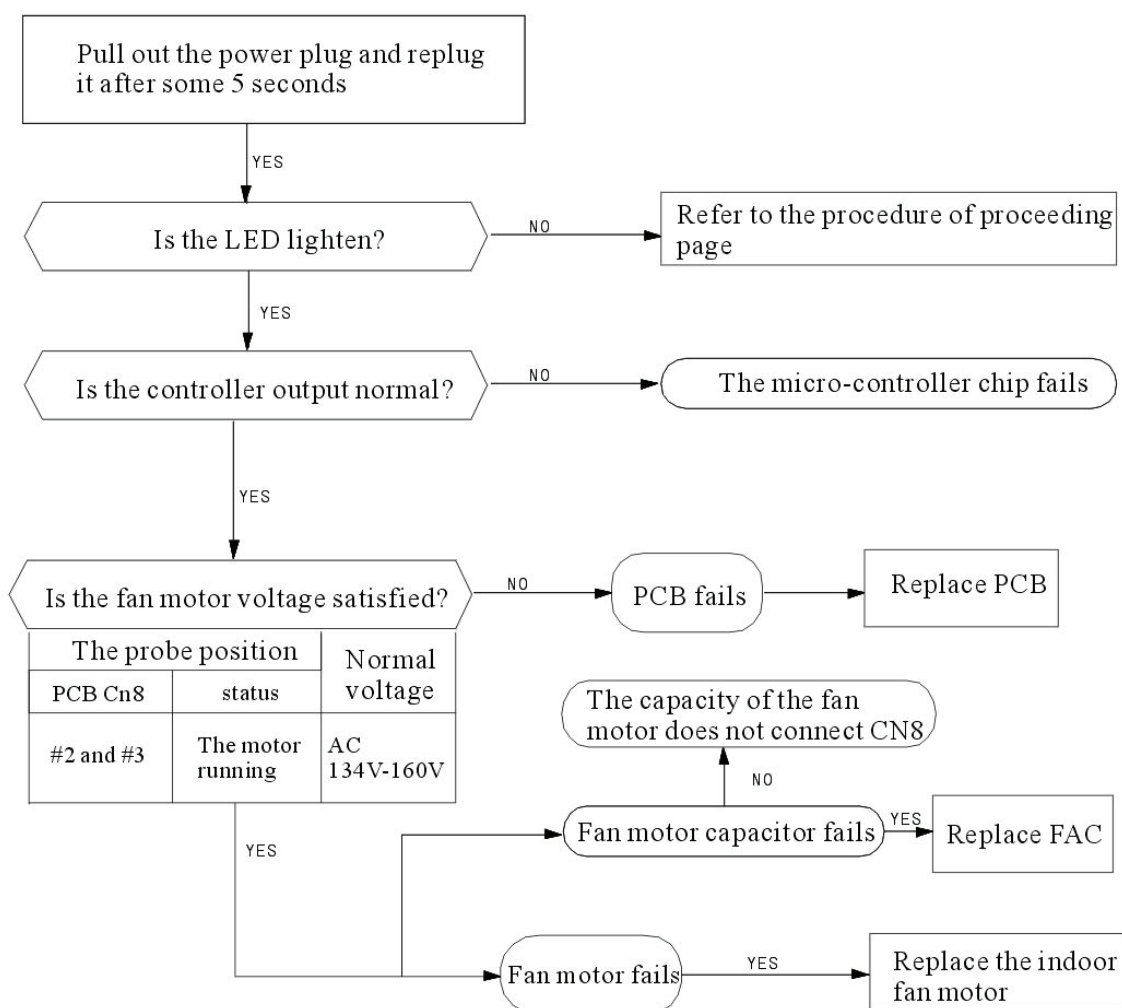

4. The Outdoor Unit Does Not Work

(1) Items

- a) Check if the input voltage is correct?
- b) Check if the wire connection of the outdoor connecting terminal is correct?

(2) Trouble shooting procedure

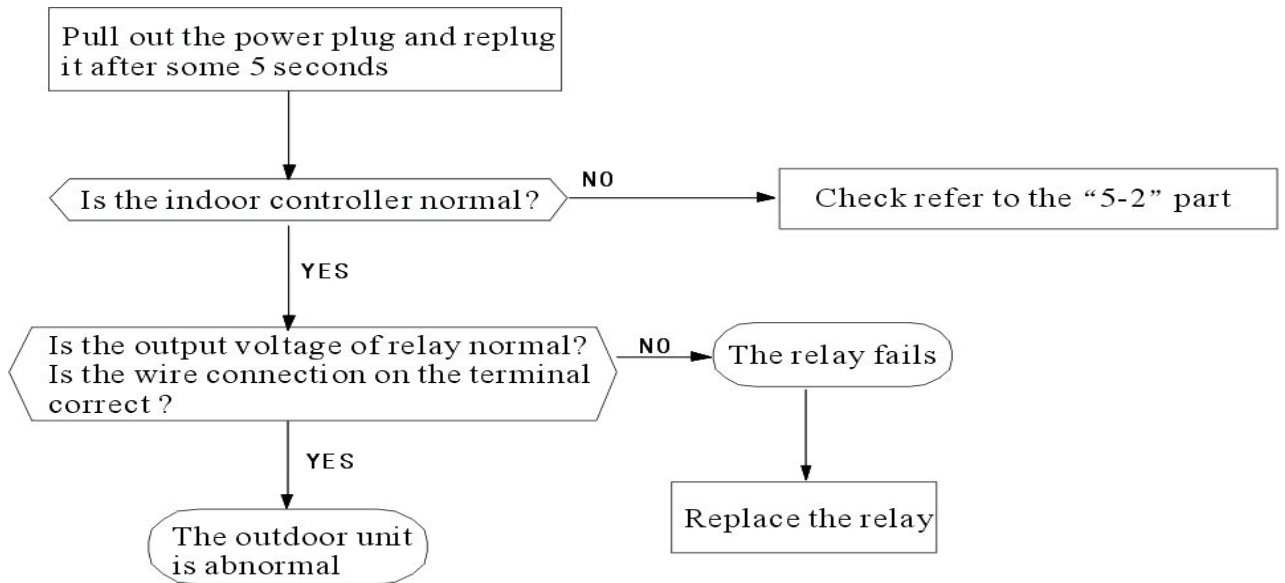

5. The Step Motor Does Not Work

(1) Items

a) Check if the input voltage is correct?

b) Check if the step motor controlling the up-down movement firmly connected to Cn2?

(2) Trouble shooting procedure

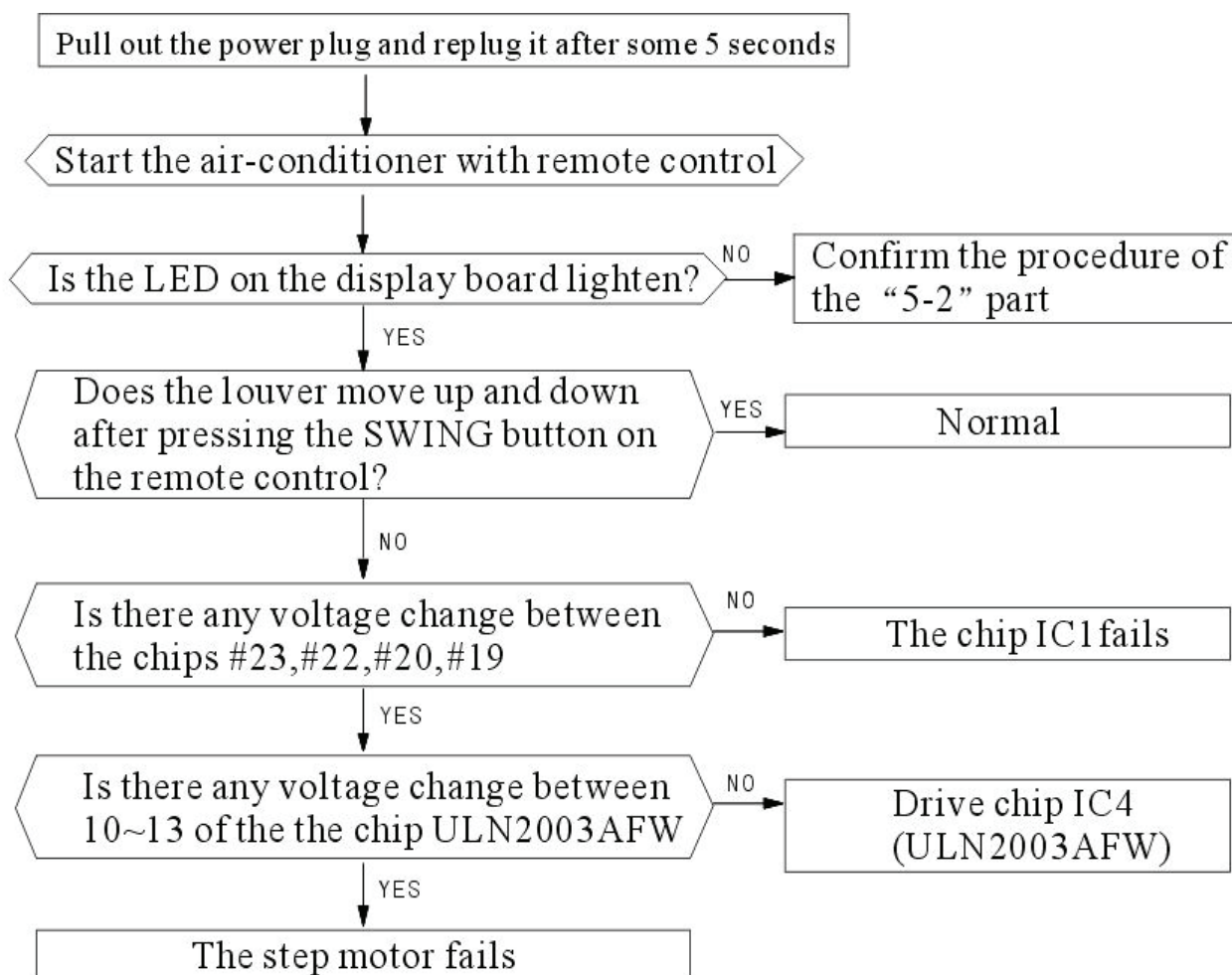

6. Heating Mode Can Work, But No Hot Air Blow

(1) Check if the set temperature is lower than the indoor temperature?

(2) Check if the indoor PCB is connected to the terminal correctly?

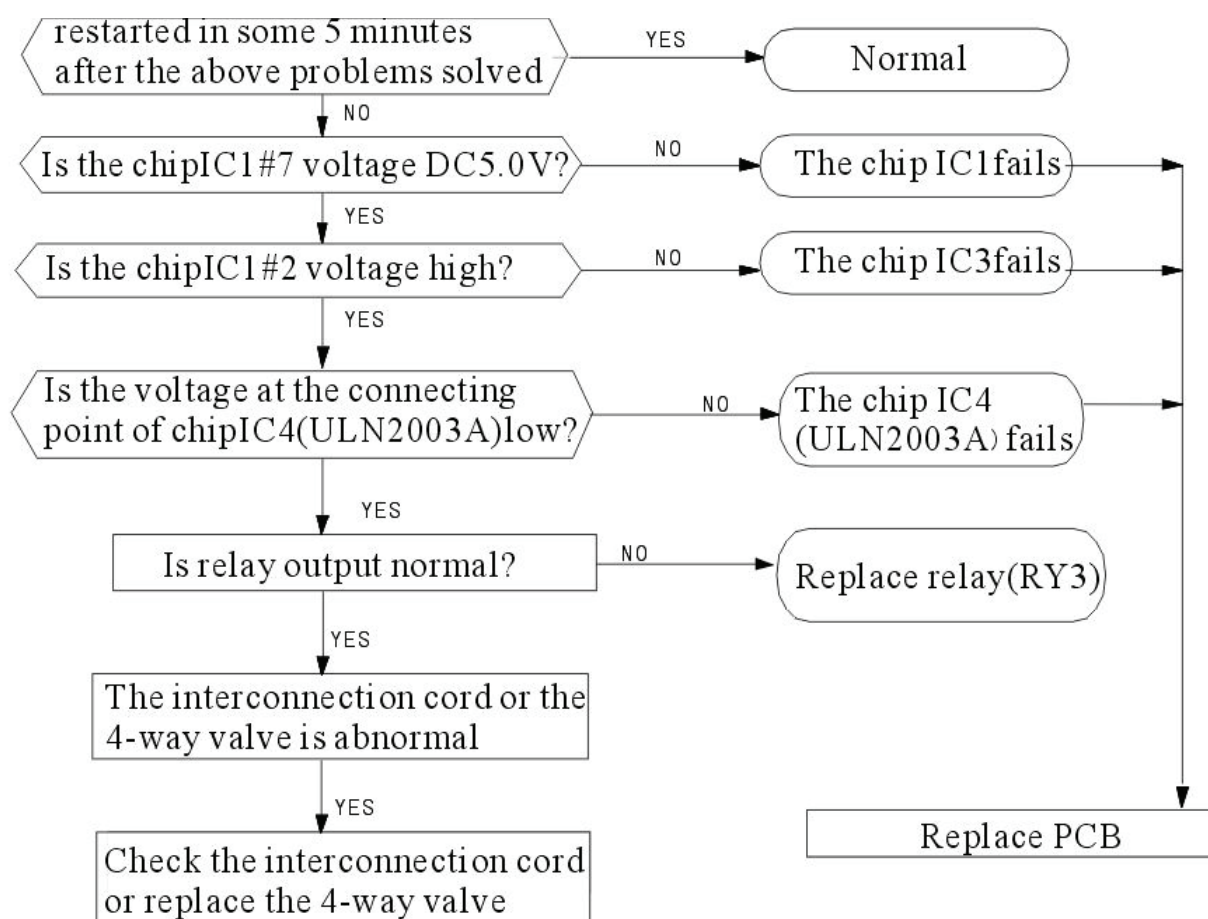

7. Remote Control Can Not Work

Trouble shooting procedure

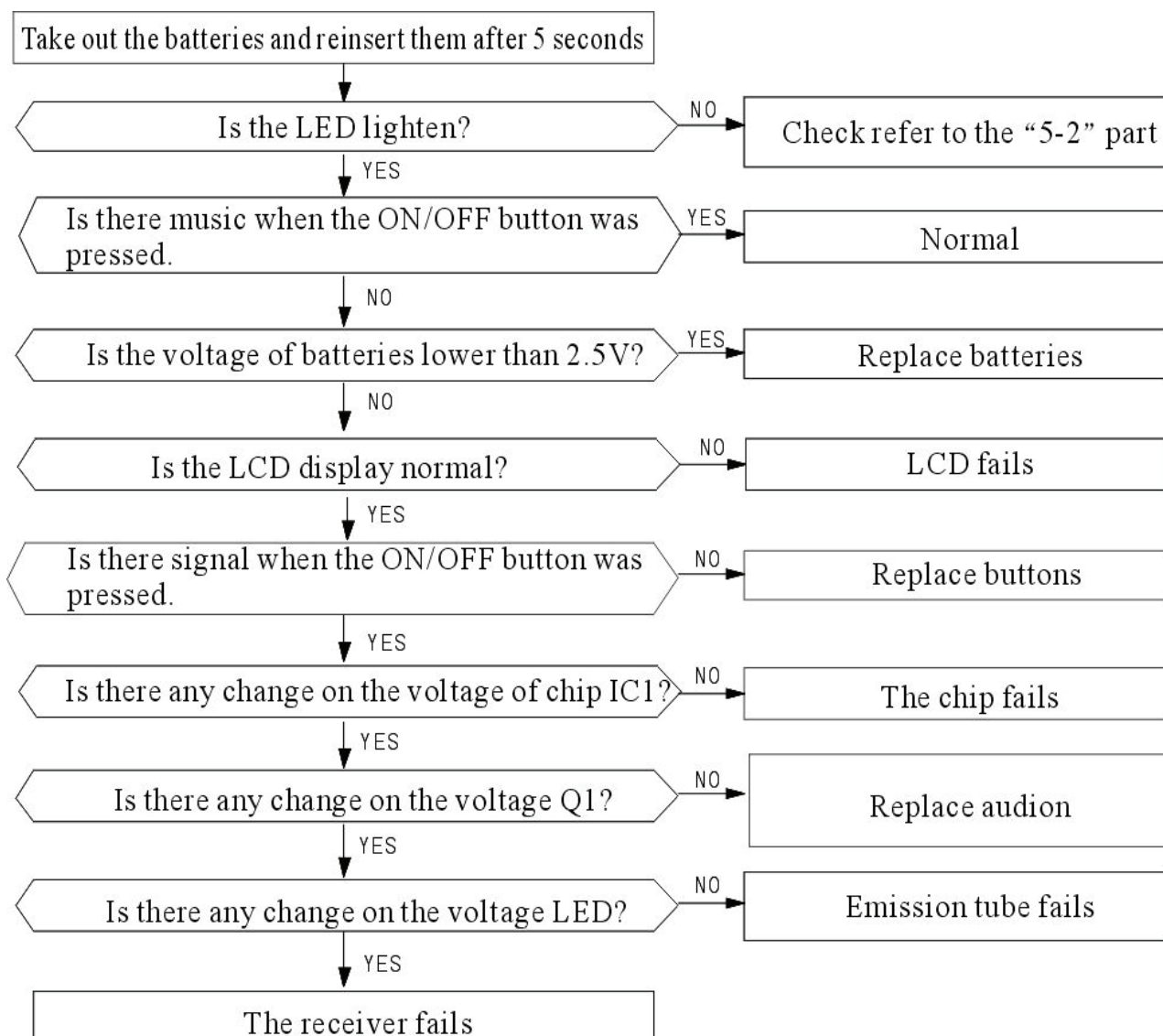

8. The Failure Analysis of the Main Parts

Part	Analysis																										
Heat exchanger	Measure resistance																										
	Normal	<table border="1"> <thead> <tr> <th>Environment temperature</th> <th>15℃</th> <th>20℃</th> <th>25℃</th> <th>30℃</th> <th>35℃</th> <th>40℃</th> </tr> </thead> <tbody> <tr> <td>Resistance of transformer(KΩ)</td> <td>7.45</td> <td>6.08</td> <td>5</td> <td>4.13</td> <td>3.43</td> <td>2.86</td> </tr> </tbody> </table>	Environment temperature	15℃	20℃	25℃	30℃	35℃	40℃	Resistance of transformer(KΩ)	7.45	6.08	5	4.13	3.43	2.86											
		Environment temperature	15℃	20℃	25℃	30℃	35℃	40℃																			
Resistance of transformer(KΩ)	7.45	6.08	5	4.13	3.43	2.86																					
Abnormal	∞: Turn-off ; 0Ω: Short-cut																										
The indoor fan motor	Detecting the resistance between each connecting terminal																										
	Normal	Environment temperature (10℃ ~30℃) <table border="1"> <thead> <tr> <th colspan="2">Between</th> <th>1</th> <th>2</th> <th>3</th> </tr> </thead> <tbody> <tr> <td>Blue、yellow</td> <td>Main</td> <td>410Ω ±10%</td> <td>350Ω ±10%</td> <td>370Ω ±10%</td> </tr> <tr> <td>Blue、red</td> <td>Auxiliary</td> <td>325Ω ±10%</td> <td>270Ω ±10%</td> <td>300Ω ±10%</td> </tr> <tr> <td colspan="2">Input</td> <td colspan="3">YYK13-4: 13W YYK19-4: 19W</td> </tr> </tbody> </table>	Between		1	2	3	Blue、yellow	Main	410Ω ±10%	350Ω ±10%	370Ω ±10%	Blue、red	Auxiliary	325Ω ±10%	270Ω ±10%	300Ω ±10%	Input		YYK13-4: 13W YYK19-4: 19W							
		Between		1	2	3																					
		Blue、yellow	Main	410Ω ±10%	350Ω ±10%	370Ω ±10%																					
		Blue、red	Auxiliary	325Ω ±10%	270Ω ±10%	300Ω ±10%																					
	Input		YYK13-4: 13W YYK19-4: 19W																								
Abnormal	∞: Turn-off ; 0Ω: Short-cut																										
Detecting the voltage between the signal wire of fan motor and ground																											
Normal	<table border="1"> <thead> <tr> <th colspan="2">Between</th> <th>Voltage</th> </tr> </thead> <tbody> <tr> <td>Gray、Orange</td> <td></td> <td>0.5V~4.5V</td> </tr> <tr> <td>Yellow、Orange</td> <td></td> <td>5V</td> </tr> </tbody> </table>	Between		Voltage	Gray、Orange		0.5V~4.5V	Yellow、Orange		5V																	
	Between		Voltage																								
Gray、Orange		0.5V~4.5V																									
Yellow、Orange		5V																									
Abnormal	voltage<0, voltage>5 is abnormal																										
Step motor	Normal	Environment temperature (10℃ ~30℃) <table border="1"> <thead> <tr> <th colspan="2">Between</th> <th>1</th> <th>2</th> <th>-</th> </tr> </thead> <tbody> <tr> <td colspan="2"></td> <td>24BYJ48</td> <td>35BYJ412B</td> <td>-</td> </tr> <tr> <td>Blue、yellow</td> <td>-</td> <td>Above 300Ω</td> <td>Around 120Ω</td> <td>-</td> </tr> <tr> <td>-</td> <td>-</td> <td>-</td> <td>-</td> <td>-</td> </tr> <tr> <td colspan="2">Input</td> <td>1.5W</td> <td>-</td> <td>-</td> </tr> </tbody> </table>	Between		1	2	-			24BYJ48	35BYJ412B	-	Blue、yellow	-	Above 300Ω	Around 120Ω	-	-	-	-	-	-	Input		1.5W	-	-
		Between		1	2	-																					
				24BYJ48	35BYJ412B	-																					
		Blue、yellow	-	Above 300Ω	Around 120Ω	-																					
-	-	-	-	-																							
Input		1.5W	-	-																							
Abnormal	∞: Turn-off ; 0Ω: Short-cut																										
The outdoor fan motor	Detecting the resistance between the red wire and every connecting end																										
	Normal	When the temperature is20℃ ~30℃ ,around 300Ω and 120Ω																									
	Abnormal	∞: Turn-off ; 0Ω: Short-cut																									

7.3 Troubleshooting Guide for 18-36K

1. The Foremost Inspecting Items

(1)The input voltage must be within +10% tolerance of the rated Voltage. If it is not the case, the air-conditioner will probably not work normally.

(2)Check the connecting cord between indoor unit and outdoor unit to see if it is properly connected. The connecting must be done according to the wiring diagram, please also notice that even different models may have the connecting cord of the same specification.

Please check if the marks at the connecting terminal and the marks on the cord can match, otherwise, the air-conditioner will not work normally.

(3)If the following phenomena are found, the problem is not from the air-conditioner itself.

NO.	Problems	Causes
1	The motor is heard operating but the air-conditioner dose not work when the indoor unit is powered on	Since the air-conditioner is powered on, it will come to working condition as long as you press the ON/OFF button of the remote control and the signal is well received.
2	The compressor stops running but the indoor fan motor keeps working when it is at cooling mode with the indoor temperature higher than set temperature.	If you turn off the air-conditioner and restart it immediately, it will return to normal in 3 minutes, after that, the air-conditioner will automatically adjust the indoor fan speed to what you set.
3	The compressor works discontinuously at dehumidifying mode.	The air-conditioner will automatically control the working of the compressor according to the inside temperature
4	The air-conditioner does not work while the LED display is on.	The TIMER is set with the air-conditioner; it will be in hold on condition. If the TIMER setting is cancelled, the air-conditioner will return to normal working condition.
5	The compressor works discontinuously at cooling and dehumidifying mode, and the indoor fan motor slows down.	The compressor stops internally or the fan motor slows down to prevent the indoor heat exchanger from being frozen.

2. No Power Display

(1) Items

- ① Check if the input voltage is correct?
- ② Check if the AC power supply connecting is correct?
- ③ Check if the output voltage of the manostat L7805(IC2) is correct?

(2) Trouble shooting procedure

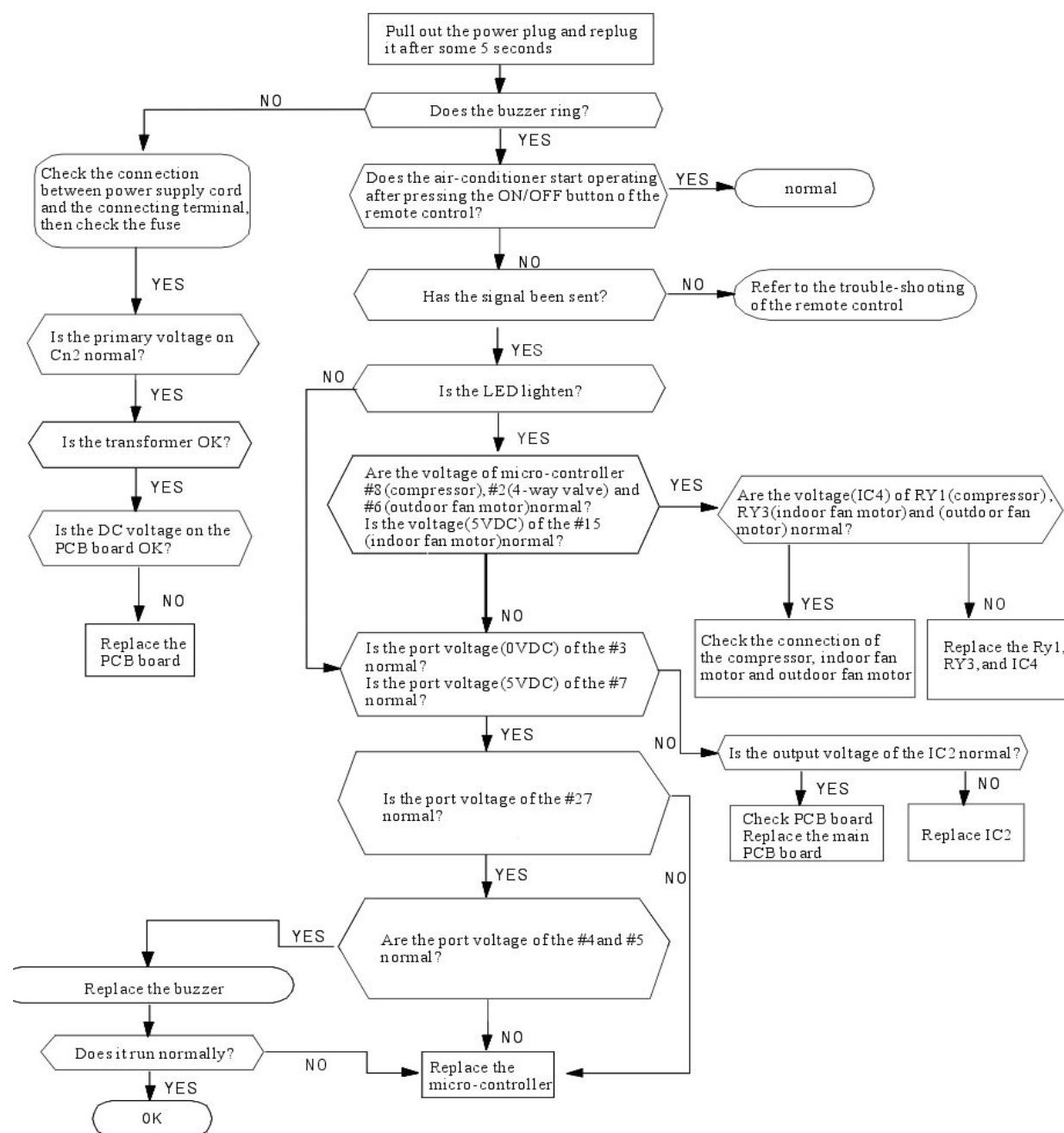

3. The Indoor Fan Motor Does Not Work

(1)Items

- ① Check if the indoor fan motor is connected correctly to the connector(CN8)?
- ② Check if the AC input voltage is correct?
- ③ Check if the IC of indoor fan motor is connected correctly to the connector(CN2)?
- ④ Check if the capacity of indoor fan motor is connected correctly to the connector(CN8)?

(2)Trouble shooting procedure

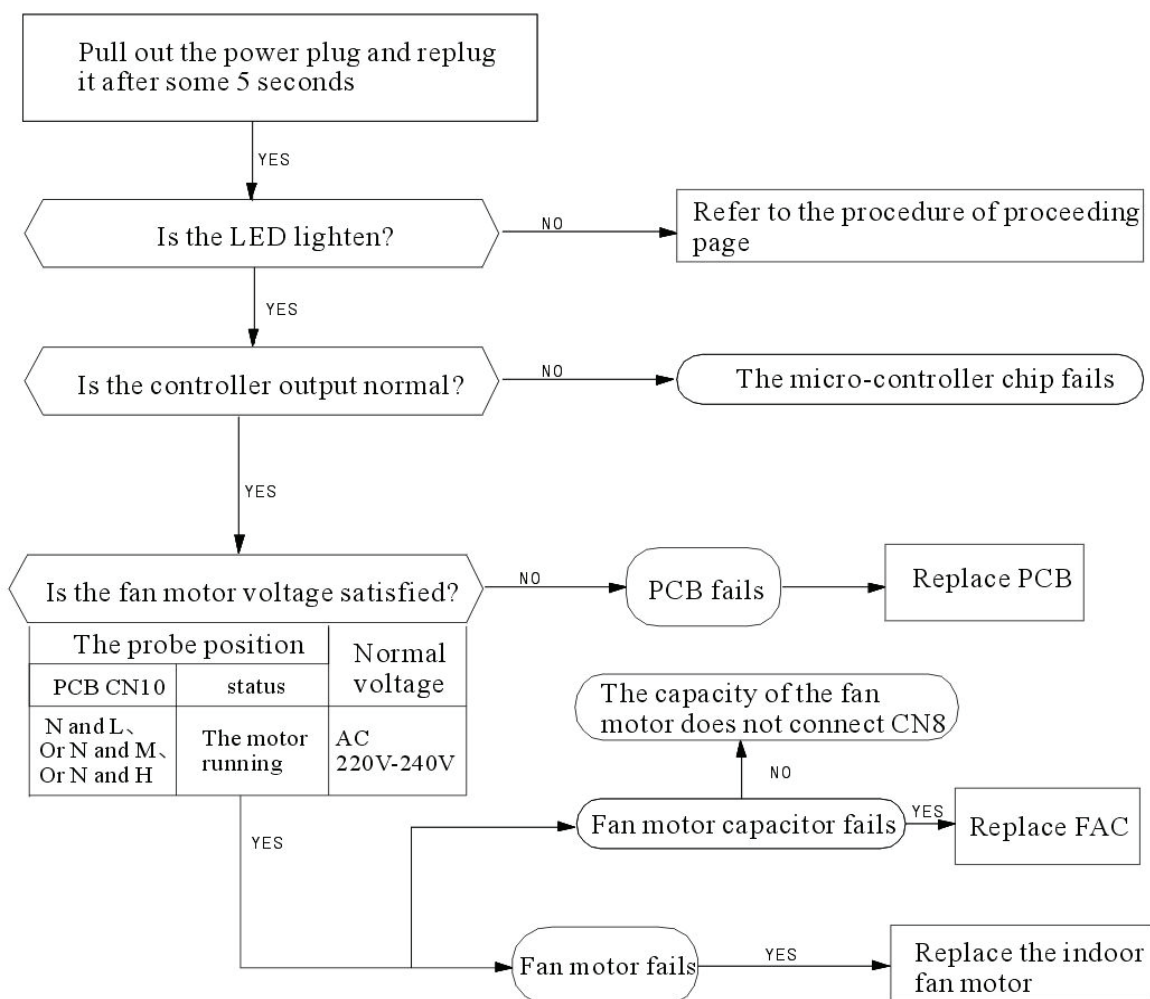

4. The Outdoor Unit Does Not Work

(1) Items

- ① Check if the input voltage is correct?
- ② Check if the wire connection of the outdoor connecting terminal is correct?

(2) Trouble shooting procedure

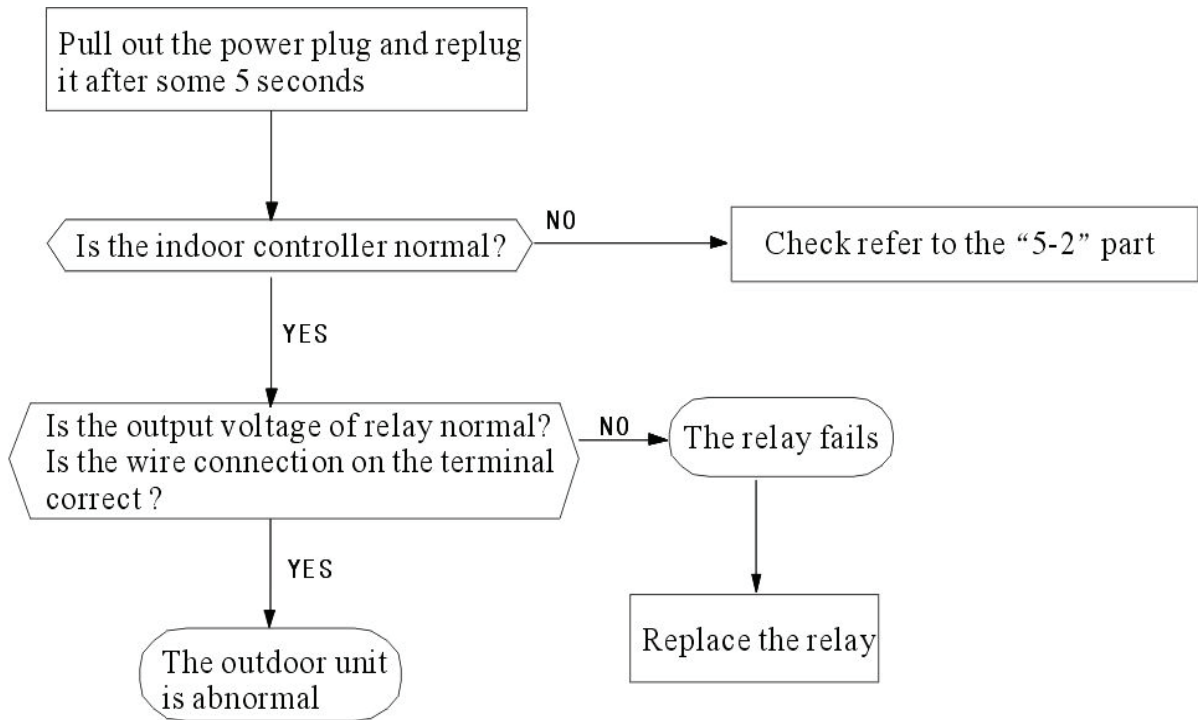

5. The Step Motor Does Not Work

(1) Items

① Check if the input voltage is correct?

② Check if the step motor controlling the up-down movement firmly connected to Cn2?

(2) Trouble shooting procedure

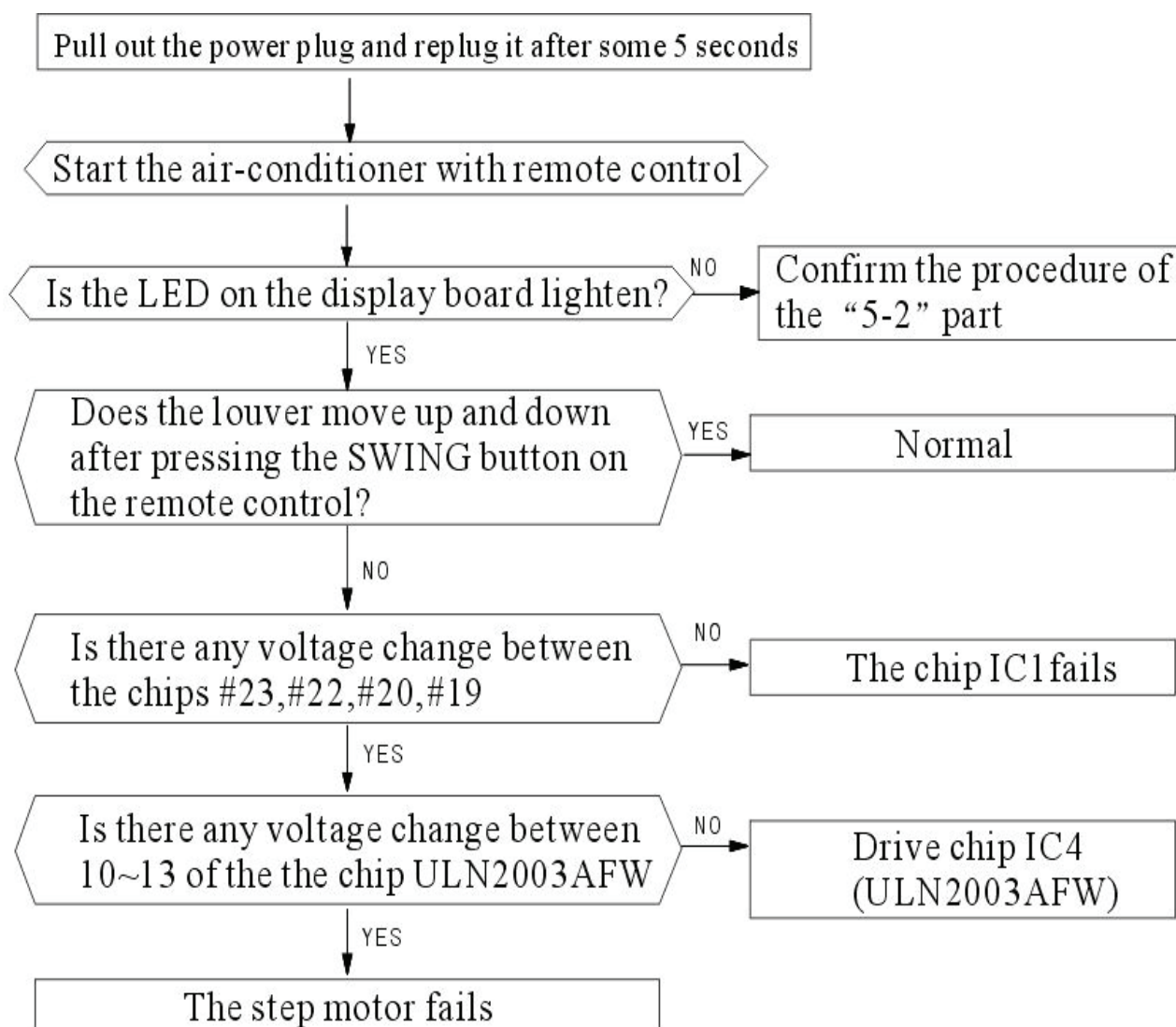

6. Heating Mode Can Work, But No Hot Air Blow

(1) Check if the set temperature is lower than the indoor temperature?

(2) Check if the indoor PCB is connected to the terminal correctly?

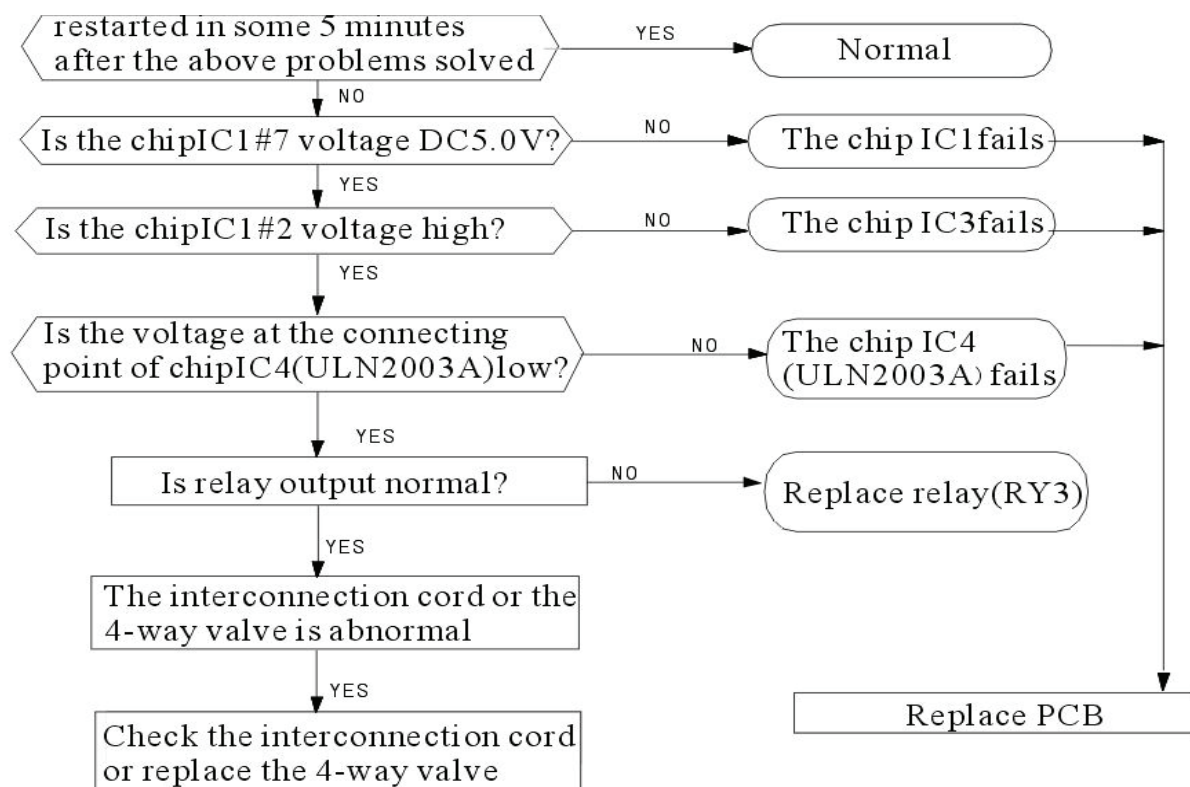

7. Remote Control Can Not Work

Trouble shooting procedure

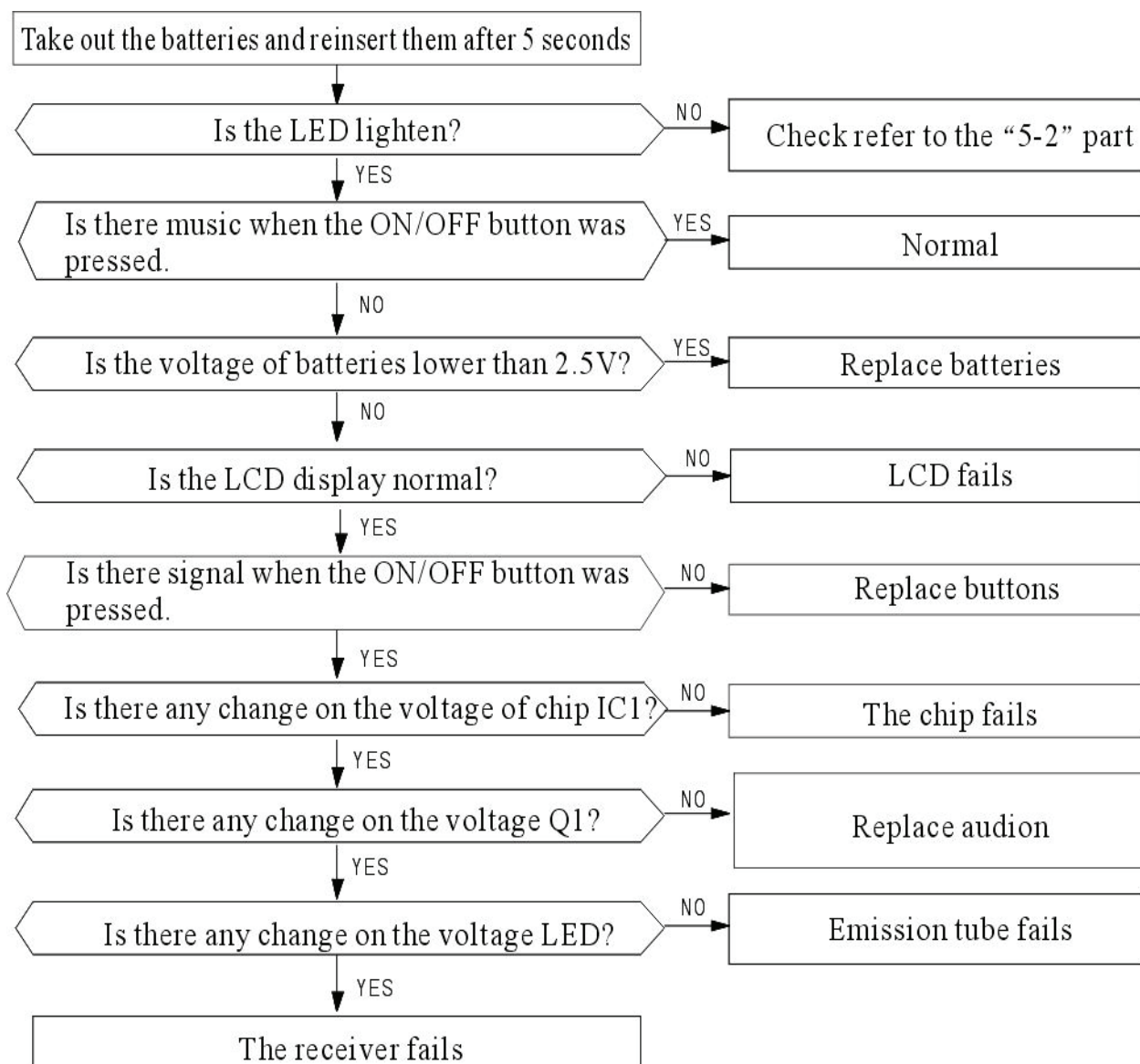

8. The Failure Analysis of the Main Parts

Part	Analysis																										
Transformer Heat exchanger	Measure resistance																										
	Normal	<table border="1"> <thead> <tr> <th>Environment temperature</th> <th>15℃</th> <th>20℃</th> <th>25℃</th> <th>30℃</th> <th>35℃</th> <th>40℃</th> </tr> </thead> <tbody> <tr> <td>Resistance of transformer(KΩ)</td> <td>7.45</td> <td>6.08</td> <td>5</td> <td>4.13</td> <td>3.43</td> <td>2.86</td> </tr> </tbody> </table>	Environment temperature	15℃	20℃	25℃	30℃	35℃	40℃	Resistance of transformer(KΩ)	7.45	6.08	5	4.13	3.43	2.86											
		Environment temperature	15℃	20℃	25℃	30℃	35℃	40℃																			
Resistance of transformer(KΩ)	7.45	6.08	5	4.13	3.43	2.86																					
Abnormal	∞ : Turn-off ; 0Ω : Short-cut																										
Step motor	Normal	Environment temperature (10℃ ~30℃)																									
		<table border="1"> <thead> <tr> <th colspan="2">Between</th> <th>1</th> <th>2</th> <th>-</th> </tr> </thead> <tbody> <tr> <td colspan="2"></td> <td>24BYJ48</td> <td>35BYJ412B</td> <td>-</td> </tr> <tr> <td>Blue, yellow</td> <td>-</td> <td>Above300Ω</td> <td>Around120Ω</td> <td>-</td> </tr> <tr> <td>-</td> <td>-</td> <td>-</td> <td>-</td> <td>-</td> </tr> <tr> <td colspan="2">Input</td> <td>1.5W</td> <td>-</td> <td>-</td> </tr> </tbody> </table>	Between		1	2	-			24BYJ48	35BYJ412B	-	Blue, yellow	-	Above300Ω	Around120Ω	-	-	-	-	-	-	Input		1.5W	-	-
		Between		1	2	-																					
		24BYJ48	35BYJ412B	-																							
Blue, yellow		-	Above300Ω	Around120Ω	-																						
-	-	-	-	-																							
Input		1.5W	-	-																							
Abnormal	∞ : Turn-off ; 0Ω : Short-cut																										
The outdoor fan motor	Detecting the resistance between the red wire and every connecting end																										
	Normal	When the temperature is20℃ ~30℃ ,around 300Ω and 120Ω																									
	Abnormal	∞ : Turn-off ; 0Ω : Short-cut																									

Chapter 8 Exploded Views & Parts List

8.1 Indoor unit for PAC9041/PAC12041

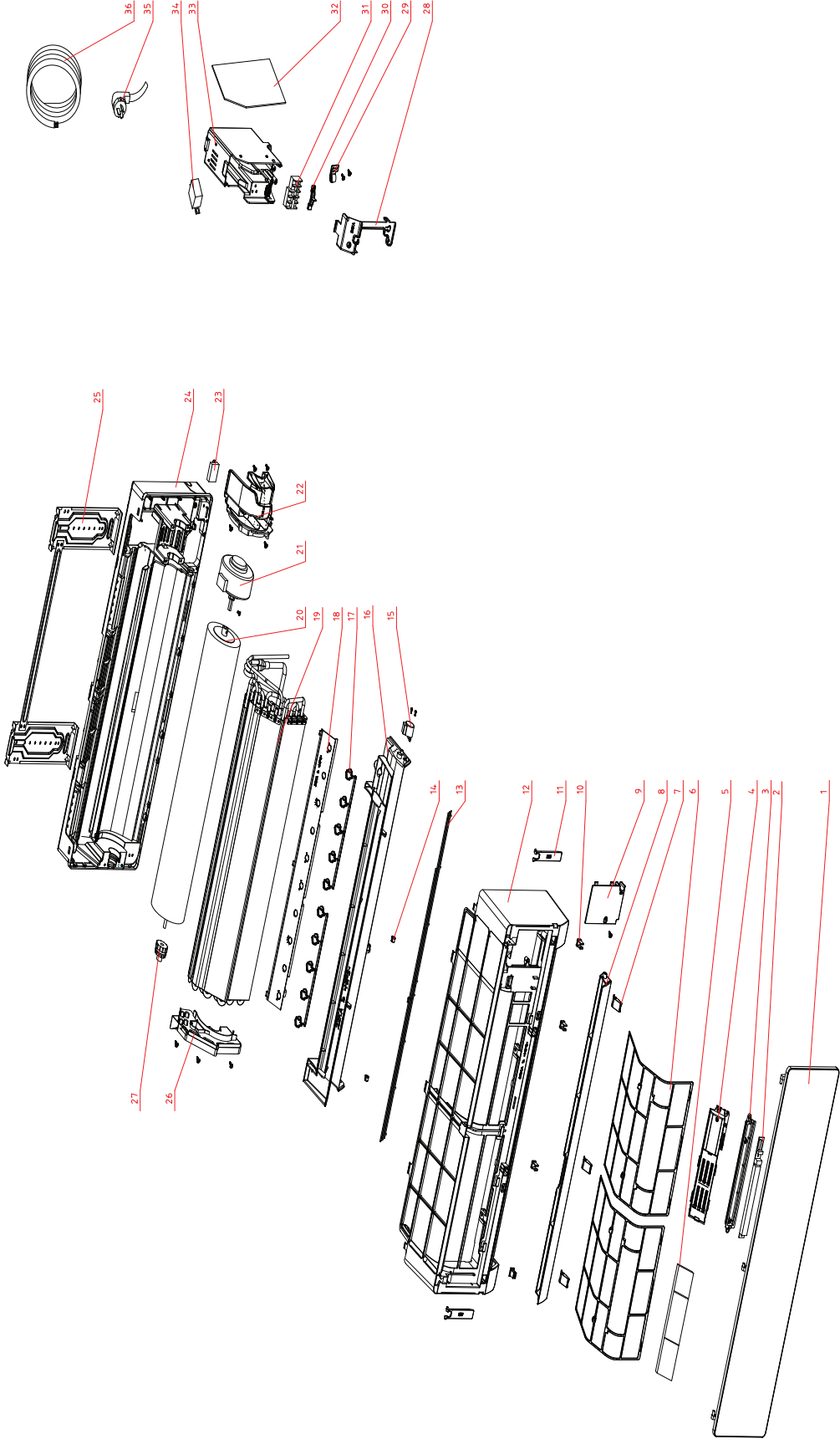

Parts List of Indoor unit for PAC9041

Exploded View No	Chinese Name	Name	Pcs	Remark
1	面板	Panel	1	
2	显示灯板组件	Display board	1	
3	显示灯座	Indication lamp holder	1	
4	静电除尘器	Electrostatic precipitator	1	
5	杀菌网	Sterilization filter	1	
6	过滤网组件	Filter	2	
7	中框螺钉盖	In box screw cap	3	
8	导风门	Horizontal air-blade	1	
9	中框盖	Cover of medium frame	1	
10	面板卡口	Panel clasper	1	
11	面板支撑杆	Stand bar	2	
12	中框	Medium frame	1	
13	钢丝网罩	Wire mesh enclosure	1	
14	轴套	sleeve	1	
15	步进电机	Step motor	1	
16	导风架	Air-vent holder	1	
17	导风叶片	Vertical air-blade	2	
18	导风叶片托板	Bracket of airflow vanes	1	
19	蒸发器组件	Evaporator assembly	1	
20	贯流风叶	Cross flow fan	1	
21	电机	Fan motor	1	
22	电机压盖	Motor cover	1	
23	负离子	Negative ion	1	
24	底座	Chassis	1	
25	挂板组件	Mounting plate	1	
26	蒸发器左支架	Left plastic-crutch for evaporator	1	
27	橡胶轴承座	Bearing holder for indoor fan	1	
28	电控盒盖	Cover of controller box	1	
29	电源线抱攀	Power supply clamp	1	
30	电源连接线压板	Connection cable clamp	1	
31	端子板	Terminal board	1	
32	主控板	Main PCB	1	
33	电控盒	Controller box	1	
34	变压器	Transformer	1	
35	电源线	Power supply	1	
36	电源连接线	Connection cable	1	

8.2.1 Outdoor unit for PAC9041

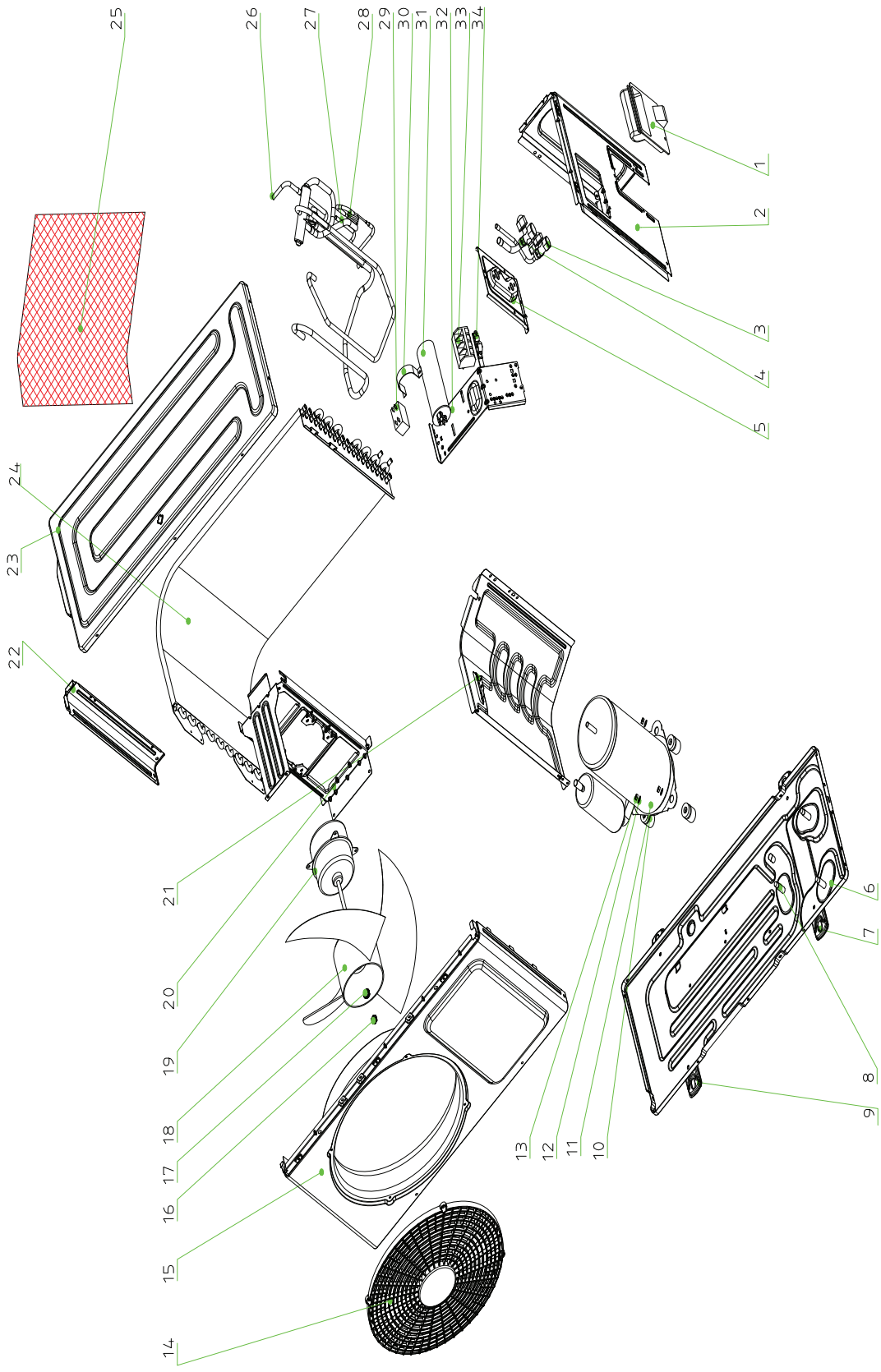

Parts List of Outdoor unit for PAC9041

Exploded View No	Chinese Name	Name	Pcs	Remarks
1	电器盖板	Electric cover	1	
2	右侧板	Right side plate	1	
3	截止阀	Gas valve assembly	1	
4	截止阀	Liquid valve assembly	1	
5	阀板	Valve plate	1	
6	底盘	Chassis assembly	1	
7	右底脚	right footing	1	
8	泵脚螺栓	Pump bolt	3	
9	左底脚	left footing	1	
10	橡胶减震垫	rubber cushion	3	
11	压缩机	Compressor assembly	1	
12	大垫圈	Big washer	3	
13	六角螺母	Hexagonal nut	3	
14	面板网罩	Front net	1	
15	面板	Panel	1	
16	六角螺母	Hexagonal nut	1	
17	轻型弹簧垫圈	Light spring washer	1	
18	室外风叶（轴流）	Propeller fan	1	
19	是外风叶电机	Fan motor	1	
20	电机架	Holder for fan motor	1	
21	隔风立板	Partition plate	1	
22	左侧支撑板	Left clapboard	1	
23	顶盖板	Top cover board	1	
24	冷凝器组件	Condensor assembly	1	
25	塑料网罩	Front net	1	
26	冷凝器进气管组件	Condenser inlet pipe assembly	1	
27	四通阀管路组件	4-Ways valve pipe assembly	1	optional (for HP)
28	毛细管管路组件	Capillary assembly	1	
29	风机电容	Fan motor capacitor	1	
30	电容抱攀	Capacitor clamp	1	
31	压缩机电容	Compressor capacitor	1	
32	电器架	Holder for E-parts	1	
33	端子板	Terminal board	1	
34	电源连接线压板	electricity cord clamp	1	

8.2.2 Outdoor unit for PAC12041

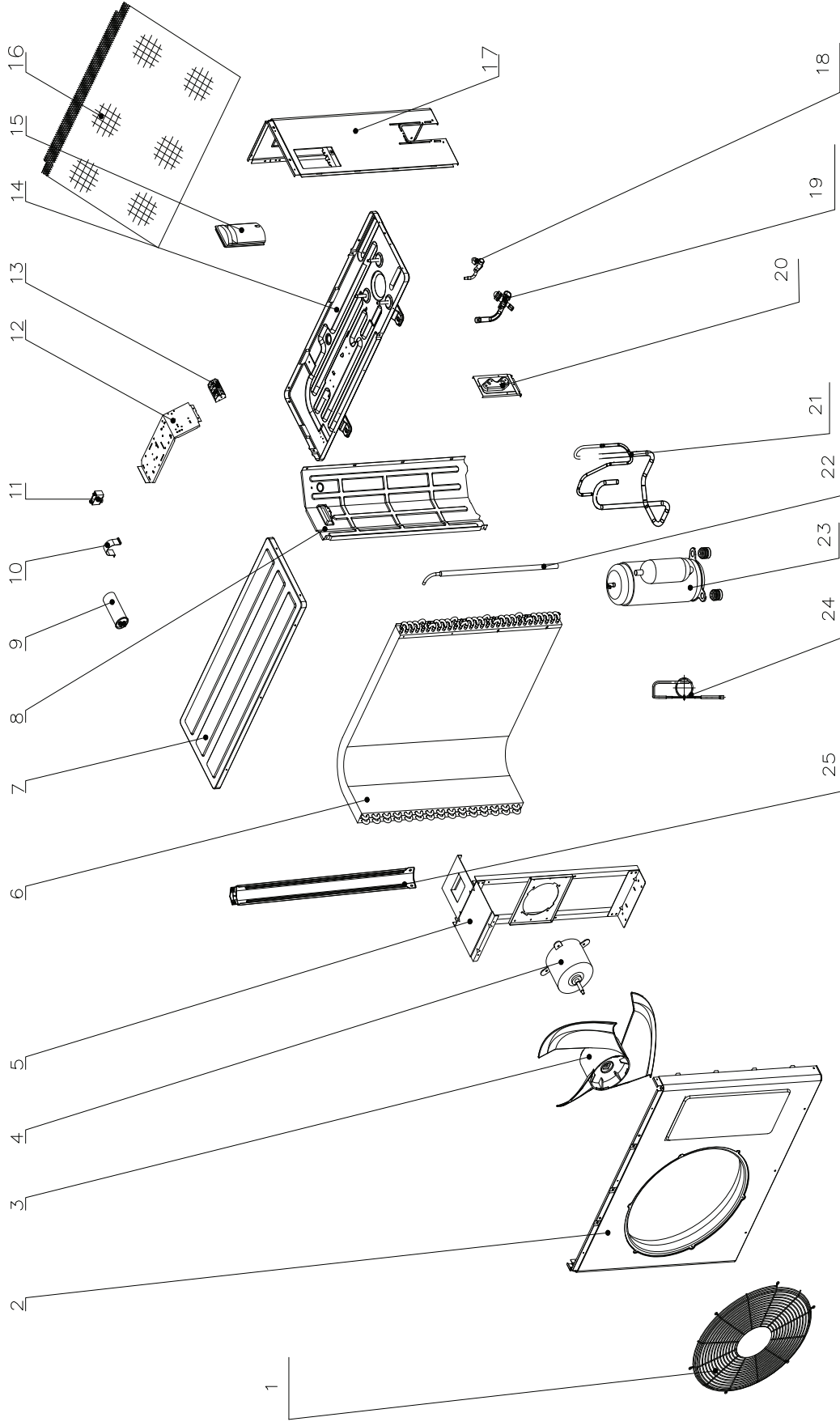

Parts List of Outdoor unit for PAC12041

Exploded View No	Chinese Name	Name	Pcs	Remark
1	面板网罩	Panel net	1	
2	面板	Panel	1	
3	轴流风叶	Axial-flow fan	1	
4	风叶电机	Fan motor	1	
5	电机架	Motor bracket	1	
6	冷凝器组件	Condenser assembly	1	
7	顶盖板	Top cover	1	
8	隔风立板	Partition plate	1	
9	压缩机电容	Compressor capacitor	1	
10	电容抱攀	Capacitor clamp	1	
11	风机电容	Fan motor capacitor	1	
12	电器架	Holder of electrical unit	1	
13	端子板	Terminal board	1	
14	底盘	Chassis assembly	1	
15	电器盖板（挖手）	Handle	1	
16	背部网罩	Back net	1	
17	右侧板	Right side plate	1	
18	液阀	Liquid valve	1	
19	气阀	Gas valve	1	
20	阀板	Valve plate	1	
21	压缩机管路组件	Compressor tubing assembly	1	
22	冷凝器进气管组件	Air inlet tube of condenser	1	
23	压缩机	Compressor	1	
24	毛细管组件	Capillary	1	
25	左侧支撑板	Left side plate	1	

8.3 Indoor unit for PAC18041

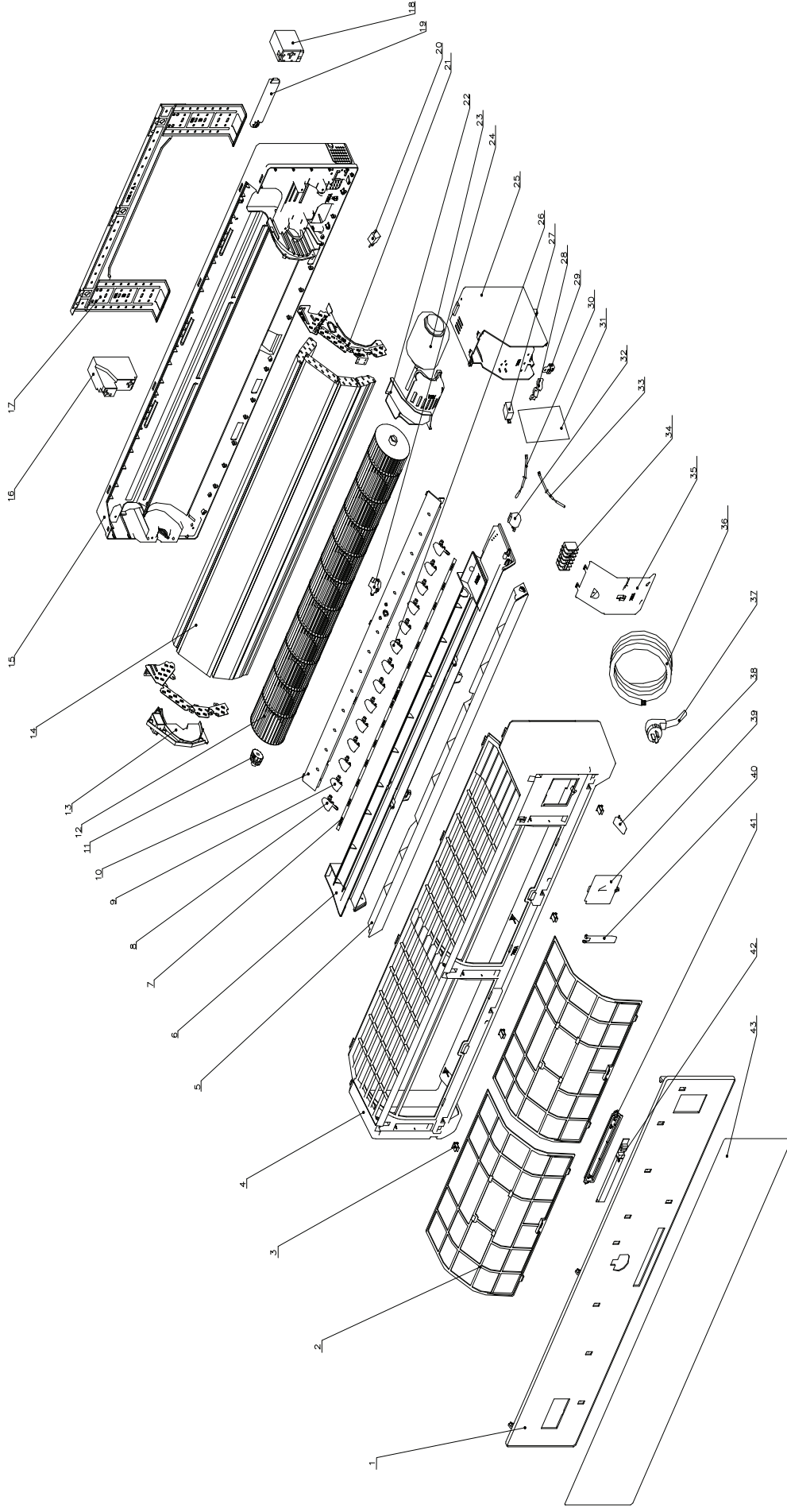

Parts List of Indoor unit for PAC18041

No	名称	Name	Quantity	Remark
1	面板	Panel	1	
2	过滤网组件	Filter	2	
3	面板卡扣	Panel clasper	3	
4	中框	Medium frame	1	
5	导风门	Horizontal airflow blade	1	
6	导风架	Air-vent holder	2	
7	导风叶片连杆	Connecting rod for airflow vanes	1	
8	导风叶片 A	Vertical airflow vanes A	7	
9	导风叶片 B	Vertical airflow vanes B	7	
10	导风叶片托板	Bracket of airflow vanes	1	
11	轴承支撑座	Bearing for indoor fan	1	
12	贯流风叶	Cross-flow fan	1	
13	蒸发器左支架	Left-hand propping holder for evaporator	1	
14	蒸发器总成	Evaporator assembly	1	
15	底座	chassis	1	
16	底座左支撑泡沫	Foam of left chassis	1	
17	挂板组件	Mounting plate	1	
18	底座右支撑泡沫	Foam of right chassis	1	
19	管路压板	Pipe clamp	1	
20	负离子发生器	Negative ion	1	
21	蒸发器右支撑板	Right-hand propping holder for evaporator	1	
22	电机压盖	Motor cover	1	
23	室内电机	Indoor fan motor	1	
24	导风叶片步进电机	Step motor of airflow vanes	1	
25	电控盒	Controller box	1	
26	导风叶片	Vertical airflow vanes	1	
27	变压器	Transformer	1	
28	电源线抱攀 A	Clamp of cable A	1	
29	电源线抱攀 B	Clamp of cable B	1	
30	温度传感器	Room temperature sensor	1	
31	PCB 板	Main PCB	1	
32	导风门步进电机	Step motor of airflow blade	1	
33	盘管温度传感器	pipe temperature sensor	1	
34	端子板	Terminal board	1	
35	电控盒盖	Cover of controller box	1	
36	电源线	Connection cable	1	
37	电源插头	Power supply plug	1	
38	螺钉盖	Screw cover	1	
39	中框接线盖	Cover of medium frame	1	
40	支撑杆	55 Stand bar	1	
41-42	显示灯板组件	Display light board assembly	1	
43	装饰面板	Panel	1	

Outdoor unit for PAC18041

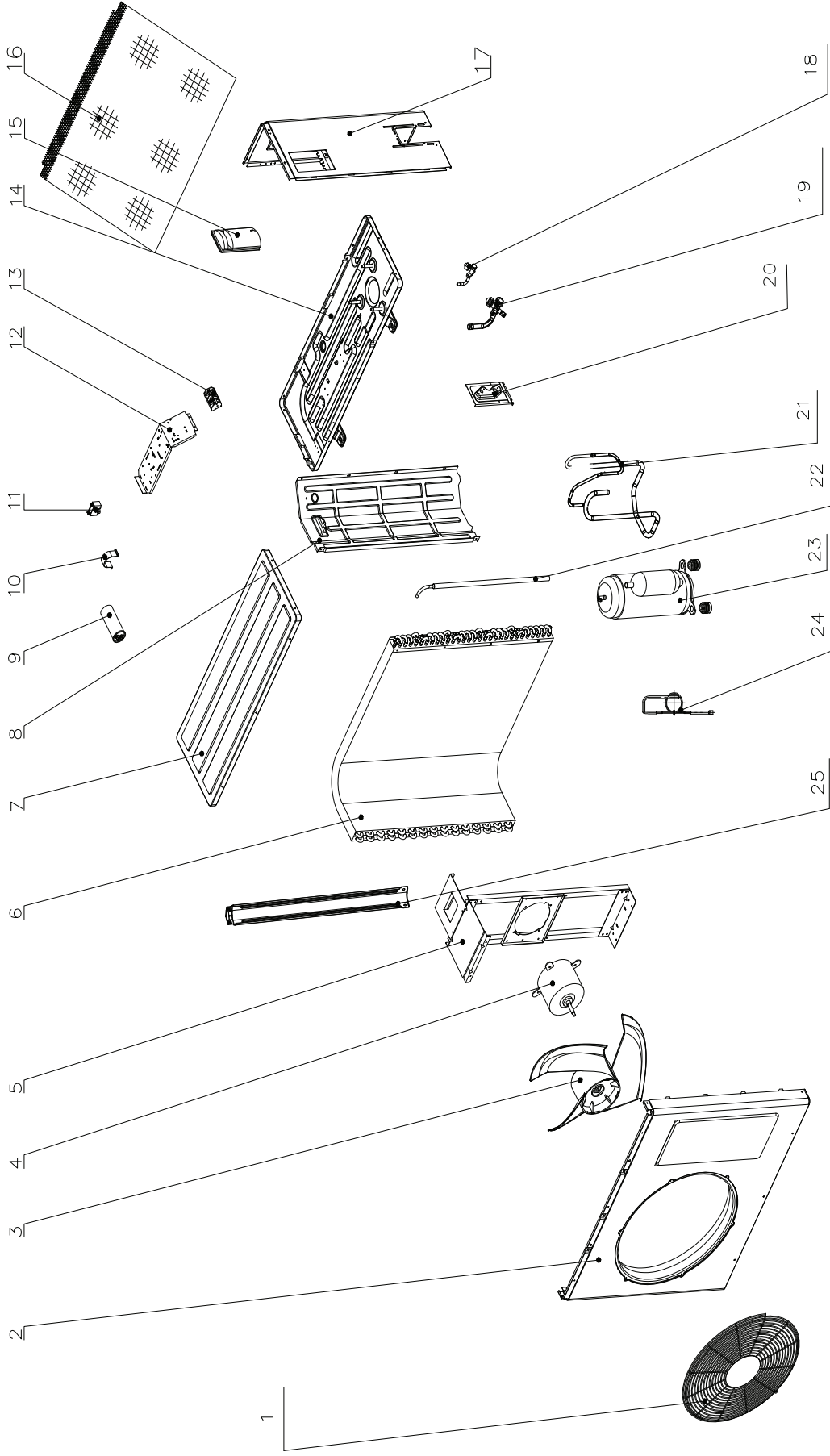

Parts List of Outdoor unit for PAC18041

NO	component	Item Description	Pcs	Remark
1	面板网罩	Panel net	1	
2	面板	Panel	1	
3	轴流风叶	Axial-flow fan	1	
4	风叶电机	Fan motor	1	
5	电机架	Motor bracket	1	
6	冷凝器组件	Condenser assembly	1	
7	顶盖板	Top cover	1	
8	隔风立板	Partition plate	1	
9	压缩机电容	Compressor capacitor	1	
10	电容抱攀	Capacitor clamp	1	
11	风机电容	Fan capacitor	1	
12	电器架	Holder of wiring unit	1	
13	端子板	Terminal board	1	
14	底盘	Chassis assembly	1	
15	电器盖板（挖手）	handle	1	
16	背部网罩	Back net	1	
17	右侧板	Right side plate	1	
18	液阀	Liquid valve	1	
19	气阀	Gas valve	1	
20	阀板	Valve plate	1	
21	压缩机管路组件	Compressor tubing assembly	1	
22	冷凝器进气管组件	Air inlet tube of condenser	1	
23	压缩机	Compressor	1	
24	毛细管组件	Capillary assembly	1	
25	左侧支撑板	Left side plate	1	

8.4 Indoor unit for PAC24041

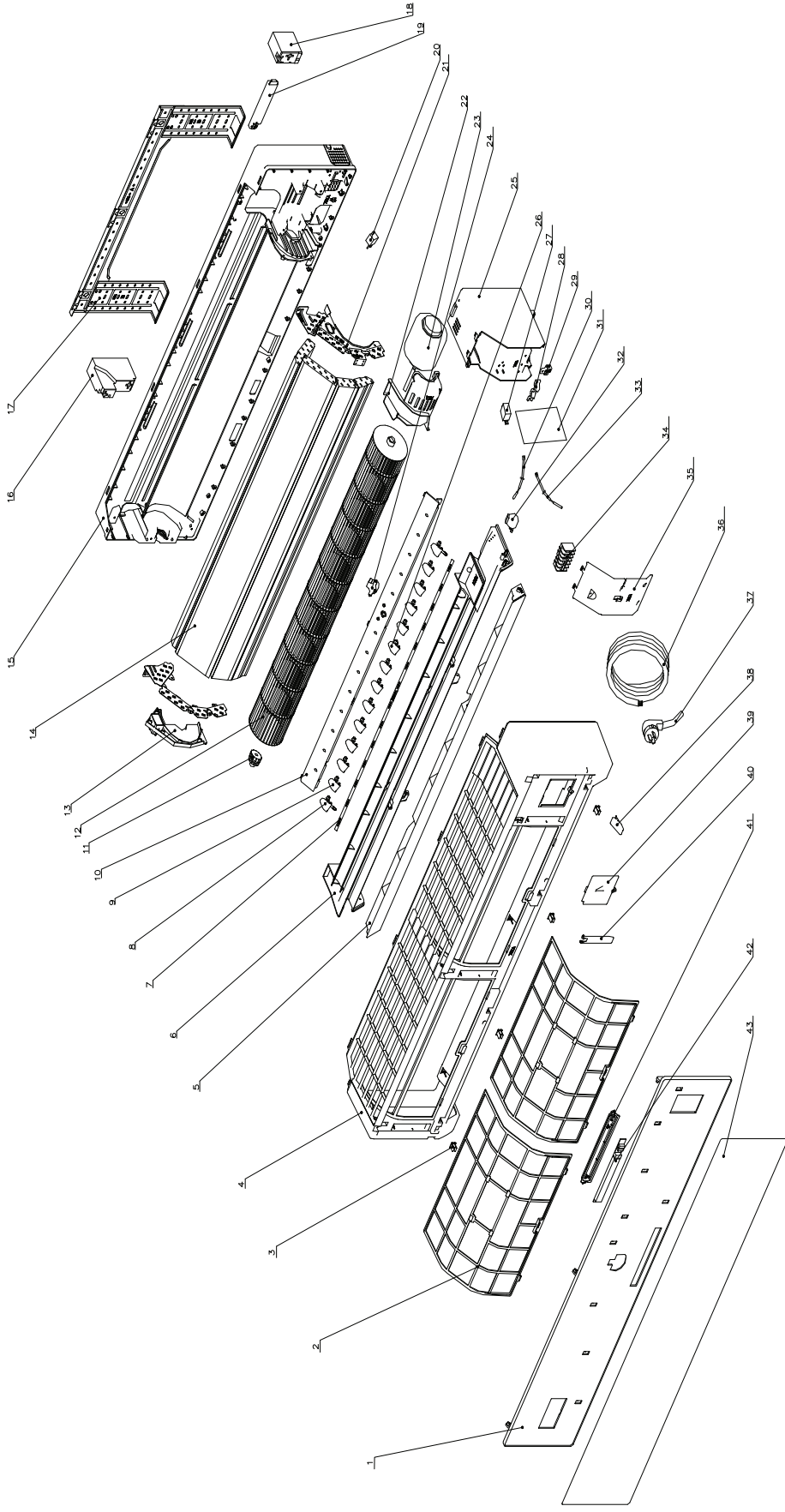

Parts List of Indoor unit for PAC24041

No	名称	Name	Quantity	Remark
1	面板	Panel	1	
2	过滤网组件	Filter	2	
3	面板卡扣	Panel clasper	3	
4	中框	Medium frame	1	
5	导风门	Horizontal airflow blade	1	
6	导风架	Air-vent holder	2	
7	导风叶片连杆	Connecting rod for airflow vanes	1	
8	导风叶片 A	Vertical airflow vanes A	7	
9	导风叶片 B	Vertical airflow vanes B	7	
10	导风叶片托板	Bracket of airflow vanes	1	
11	轴承支撑座	Bearing for indoor fan	1	
12	贯流风叶	Cross-flow fan	1	
13	蒸发器左支架	Left-hand propping holder for evaporator	1	
14	蒸发器总成	Evaporator assembly	1	
15	底座	chassis	1	
16	底座左支撑泡沫	Foam of left chassis	1	
17	挂板组件	Mounting plate	1	
18	底座右支撑泡沫	Foam of right chassis	1	
19	管路压板	Pipe clamp	1	
20	负离子发生器	Negative ion	1	optional
21	蒸发器右支撑板	Right-hand propping holder for evaporator	1	
22	电机压盖	Motor cover	1	
23	室内电机	Indoor fan motor	1	
24	导风叶片步进电机	Step motor of airflow vanes	1	
25	电控盒	Controller box	1	
26	导风叶片	Vertical airflow vanes	1	
27	变压器	Transformer	1	
28	电源线抱攀 A	Clamp of cable A	1	
29	电源线抱攀 B	Clamp of cable B	1	
30	内环探头	Room temperature sensor	1	
31	PCB 板	Main PCB	1	
32	导风门步进电机	Step motor of airflow blade	1	
33	盘管探头	pipe temperature sensor	1	
34	端子板	Terminal board	1	
35	电控盒盖	Cover of controller box	1	
36	电源线	Connection cable	1	
37	电源插头	Power supply plug	1	
38	螺钉盖	Screw cover	1	
39	中框接线盖	Cover of medium frame	1	
40	支撑杆	Stand bar	1	
41	显示灯座	Holder of display board	1	
42	显示屏	Display screen	1	
43	面板	Panel	1	

Outdoor unit for PAC24041

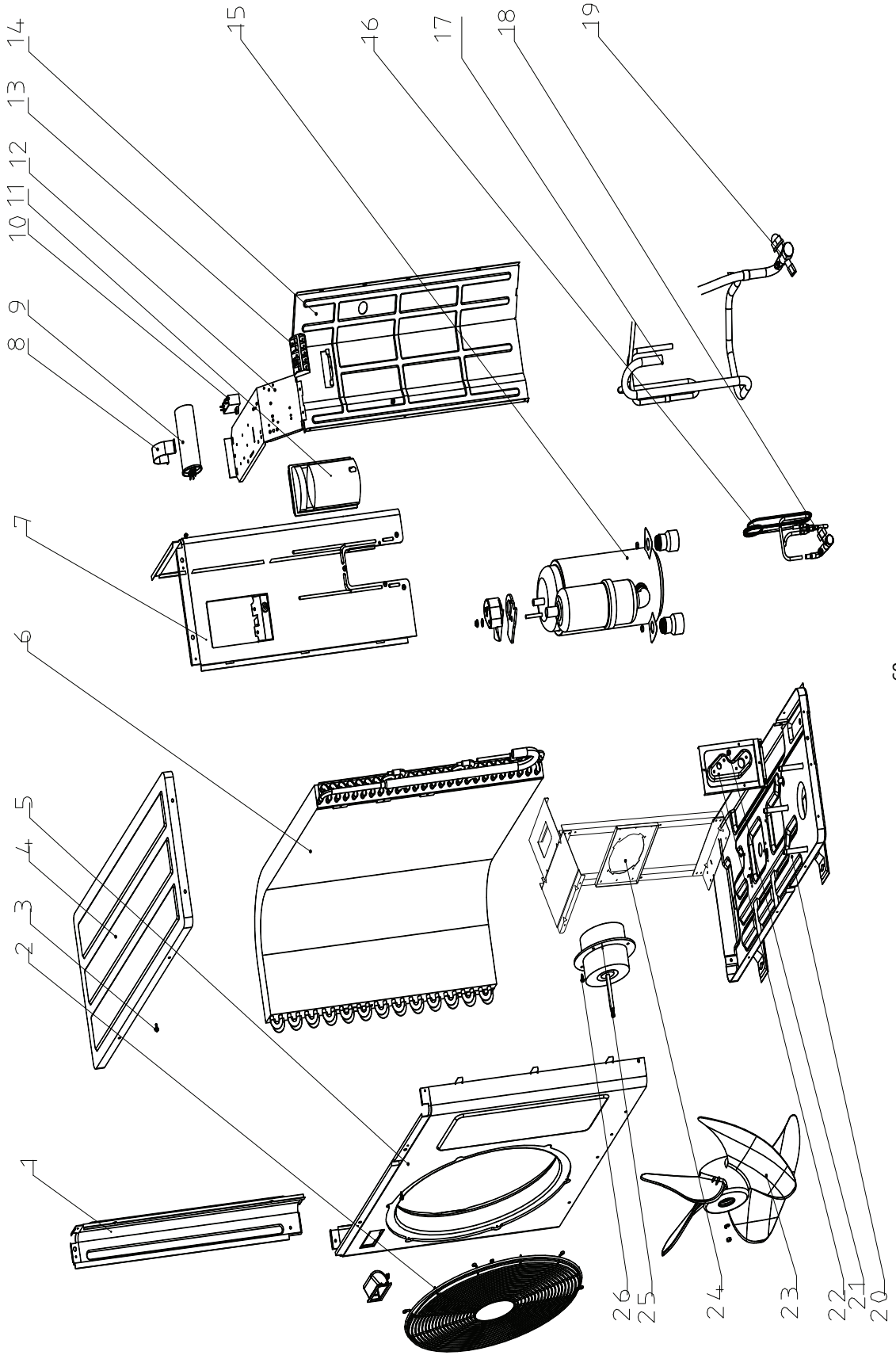

Parts List of Outdoor unit for PAC24041

Exploded View No	Chinese Name	Name	Pcs	Remark
1	左支撑板	Left clapboard	1	
2	钢丝网罩	Front net	1	
3	大扁头自攻螺钉	Big flat head self-drilling screw	40	
4	顶盖板	Top cover board	1	
5	大面板	Panel	1	
6	冷凝器总成	Condensor assembly	1	
7	右侧板	Right side plate	1	
8	电容抱攀	Capacitor clamp	1	
9	压缩机电容	Compressor capacitor	1	
10	电机电容	Fan motor capacitor	1	
11	压线盖	Electric cover	1	
12	电器架	Holder for E-parts	1	
13	五位端子板	Terminal board	1	
14	隔风立板	Partition plate	1	
15	压缩机组件	Compressor assembly	1	
16	毛细管管路组件	Capillary assembly	1	
17	压缩机管路组件	Compressor pipe assembly	1	
18	截止阀组件	Liquid valve assembly	1	
19	截止阀组件	Gas valve assembly	1	
20	底盘组件	Chassis assembly	1	
21	十字槽凹穴六角头自攻螺钉和平垫圈组合件	Phillips screw	4	
22	阀板	Valve plate	1	
23	轴流风扇	Propeller fan	1	
24	电机架	Holder for fan motor	1	
25	室外风叶电机组件	Fan motor	1	
26	十字槽盘头自攻螺钉	Phillips pan head self-drilling screw	1	

AUX 宁波奥克斯空调有限公司

ADD: No556, east Yinzhou Greatroad, Ningbo, P.R. China

Tel: +86(574)8822 0156 Fax: +86(574)8822 0683

Code: 315100

Http://www.cnaux.com