

5K

37	Electric box fireproofing cover	F
36	Electric Box Cover	F
35	Thermostat	W
34	Control Switch	W
33	Terminal Board	F
32	Capacitor CBB65	F
31	Electric Box	F
30	Electric Box Assy	F
29	Power Cord	F
28	Chassis Sub-assy	H
27	Chassis Assy	H
26	Membrane	F
25	Knob Sub-Assy	F
24	Switch Cover	F
23	Front Panel Assy	F
22	Filter Sub-Assy	F
21	Front Panel	F
20	Air Louver	F
19	Gear wheel	F
18	Impeller inducer clamp	F
17	Foam Assy	F
16	Capillary Sub-Assy	F
15	Evaporator Assy	F
14	Upper Propeller sub-assy	F
13	Discharge Tube	F
12	Compressor Gasket	F
11	Overload Protector	F
10	Compressor and fittings	F
9	Inhalation Tube	F
8	Centrifugal fan	F
7	Air flue assy	F
6	Rear Clapboard	F
5	Fan Motor	F
4	Axial Flow Fan	F
3	Condenser Assy	F
2	Cabinet	F
1	Cabinet Sub-assy	F
序号	物料英文名	

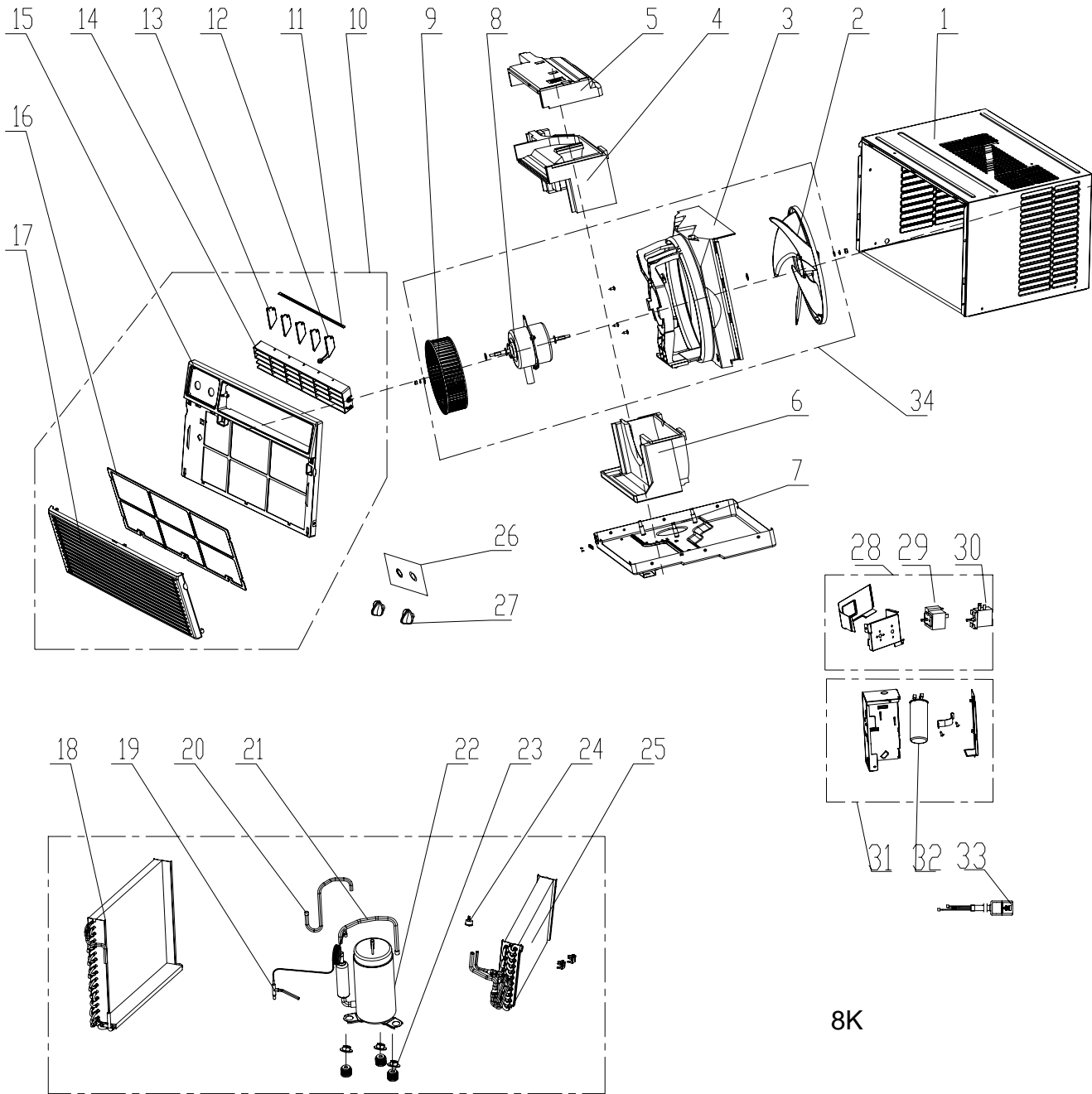

34	Air flue assy
33	Power Cord
32	Capacitor CBB65
31	Electric Box Assy
30	Thermostat
29	Controll Switch
28	Electric box assy 1
27	Knob Sub-Assy
26	Membrane
25	Evaporator Assy
24	Overload Protector
23	Compressor Gasket
22	Compressor and fittings
21	Inhalation Tube
20	Discharge Tube
19	Capillary Sub-Assy
18	Condenser Assy
17	Air intake Panel
16	Filter Sub-Assy
15	Front Case
14	Air guide frame
13	Air Louver 2
12	Air Louver 1
11	Swing lever
10	Front panel assy (main control)
9	Centrifugal fan
8	Fan Motor
7	Chassis Assy
6	Propeller Housing(lower)
5	Propeller Housing (upper)
4	Propeller Housing (mid)
3	Rear Clapboard
2	Axial Flow Fan
1	Cabinet

8K

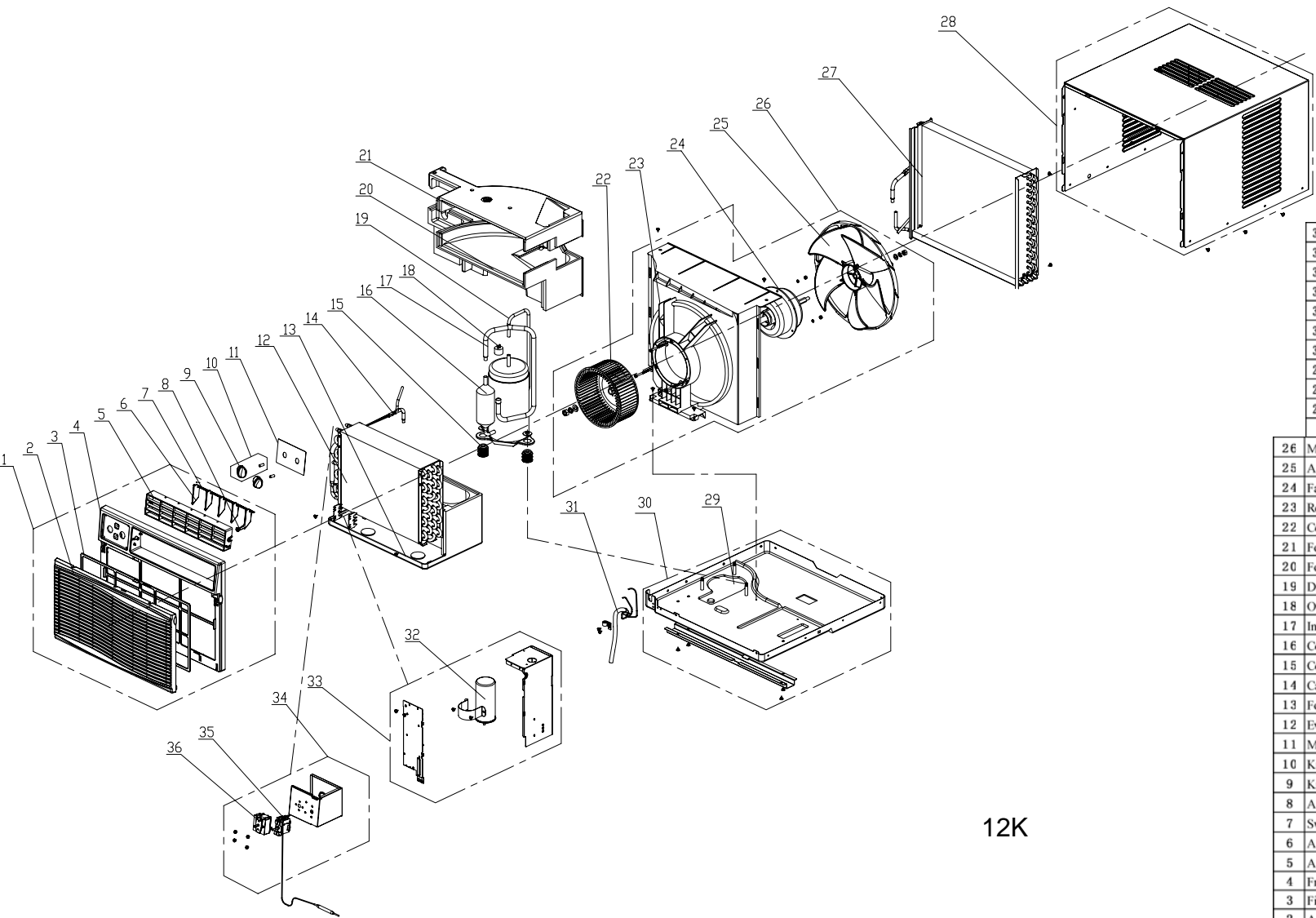

36	Controll Switch
35	Thermostat
34	Electric box Assy 2
33	Electric box Assy 1
32	Capacitor CBB65
31	Power Cord
30	Chassis Assy
29	Chassis Sub-assembly
28	Cabinet Assy
27	Condenser Assy
	物料英文名

26	Motor Support Sub-Assembly
25	Axial Flow Fan
24	Fan Motor
23	Rear Clapboard
22	Centrifugal fan
21	Foam (Propeller Housing cover)
20	Foam (Propeller Housing)
19	Discharge Tube
18	Overload Protector
17	Inhalation Tube
16	Compressor and fittings
15	Compressor Casket
14	Capillary Assy
13	Foam (water tray)
12	Evaporator Assy
11	Membrane (Switch)
10	Knob Sub-Assembly
9	Knob
8	Air Louver 1
7	Swing lever
6	Air Louver 2
5	Air guide frame
4	Front Case
3	Filter Sub-Assembly
2	Air intake Panel
1	Front Panel Assy

12K